

				IMPIANTO	TITOLO		N. DIS. COMM.DWG		FOGLIO	SEGUE
				Q.E. COMMUTAZIONE RETE/GE	COMMUTAZIONE TETRAPOLARE		N. ARCH.		1	2
				GREEN POWER SYSTEMS Srl	SCHEMA	RIF. CLIENTE	DATA		TOT. FOGLI	
REV.	DATA	OGGETTO MODIFICA	FIRMA	COMM		FIRMA	21/12/2006		5	
							SCALA			

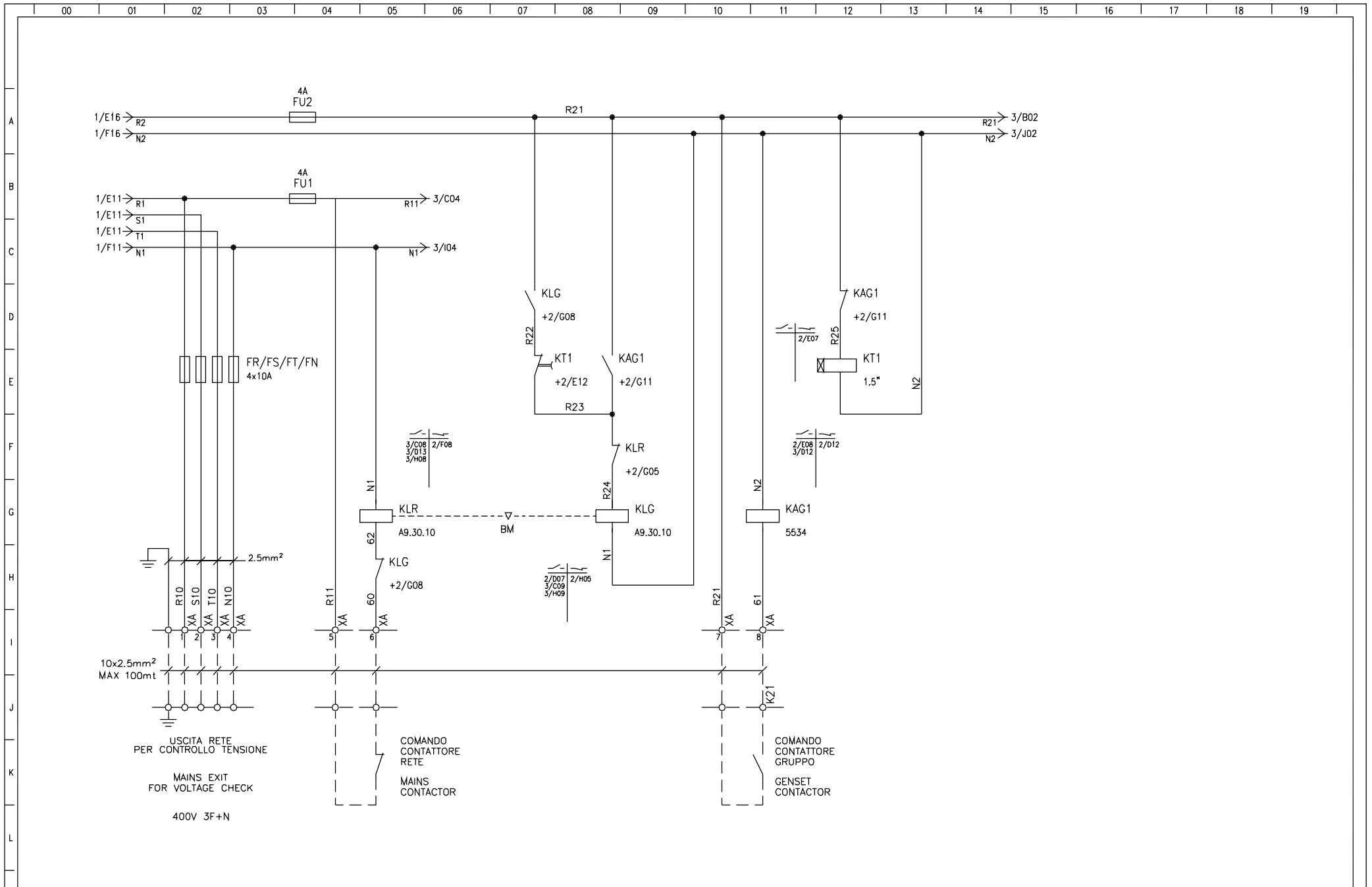

IMPIANTO			TITOLO		DISEGNATORE		N. DIS. COMM.DWG		FOGLIO		SEGUE
Q.E. COMMUTAZIONE RETE/GE			AUSILIARI COMANDO COMMUTAZIONE		AB		N. ARCH.		2		3
GREEN POWER SYSTEMS Srl			SCHEMA		FIRMA		DATA		21/12/2006		TOT. FOGLI
REV.	DATA	OGGETTO MODIFICA	FIRMA	COMM	RIF. CLIENTE	SCALA	5				

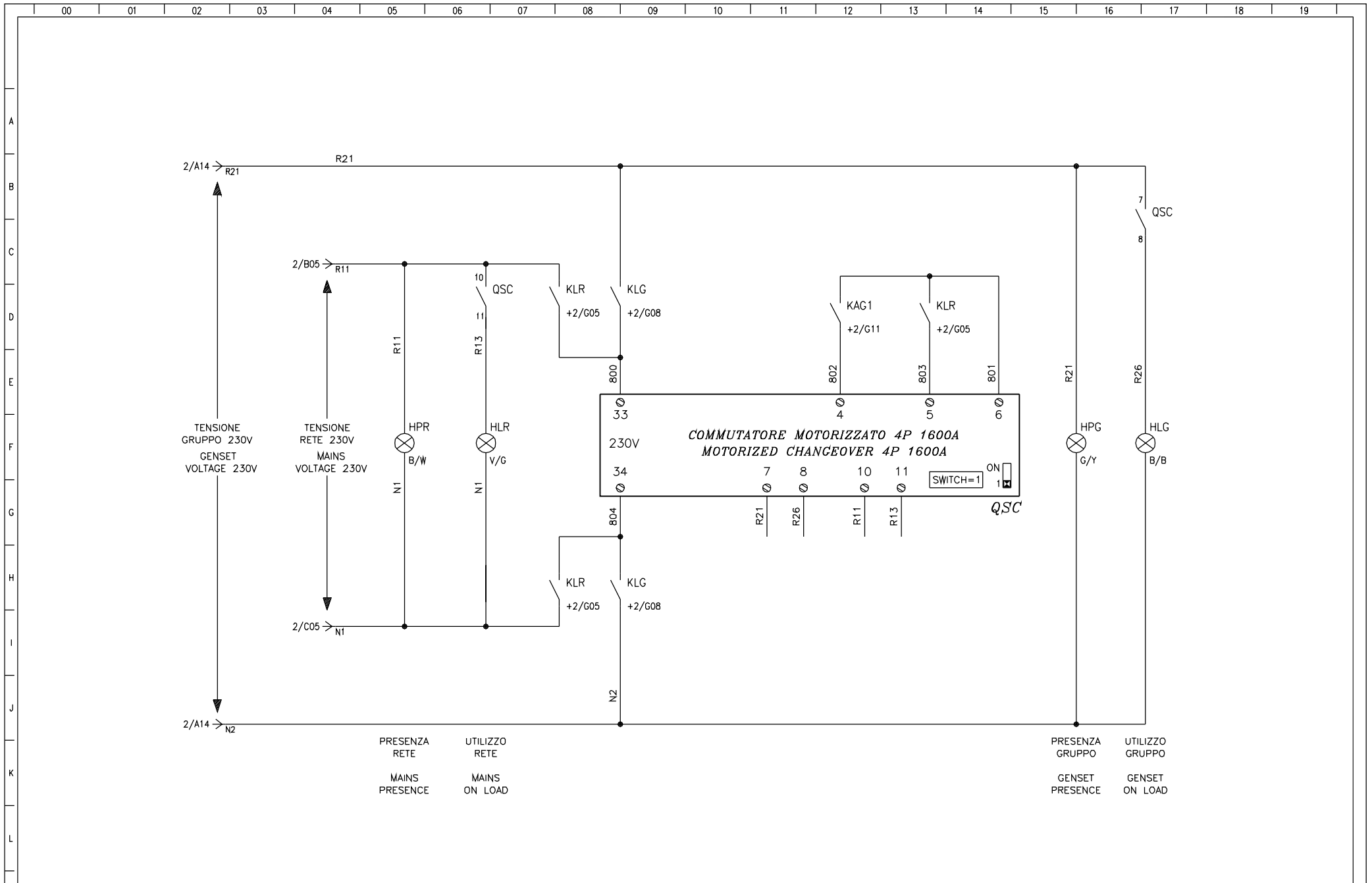

				IMPIANTO Q.E. COMMUTAZIONE RETE/GE	TITOLO TOPOGRAFICO QUADRO	DISEGNATORE AB	N. DIS. COMM.DWG N. ARCH.	FOGLIO 3	SEGUE 4
REV.	DATA	OGGETTO MODIFICA	FIRMA	GREEN POWER SYSTEMS Srl	SCHEMA COMM	RIF. CLIENTE	DATA 21/12/2006	TOT. FOGLI 5	
						FIRMA	SCALA		

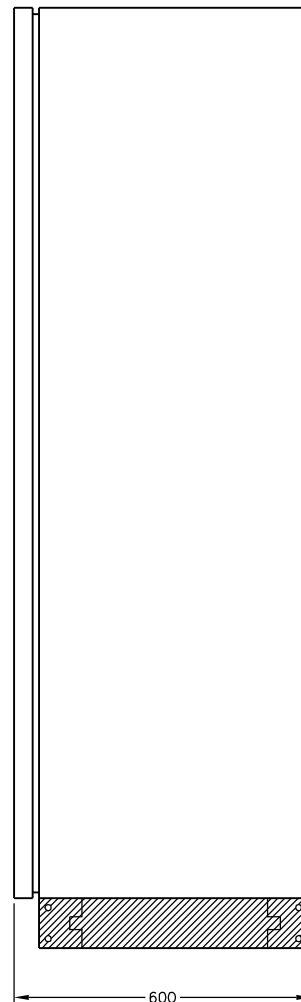
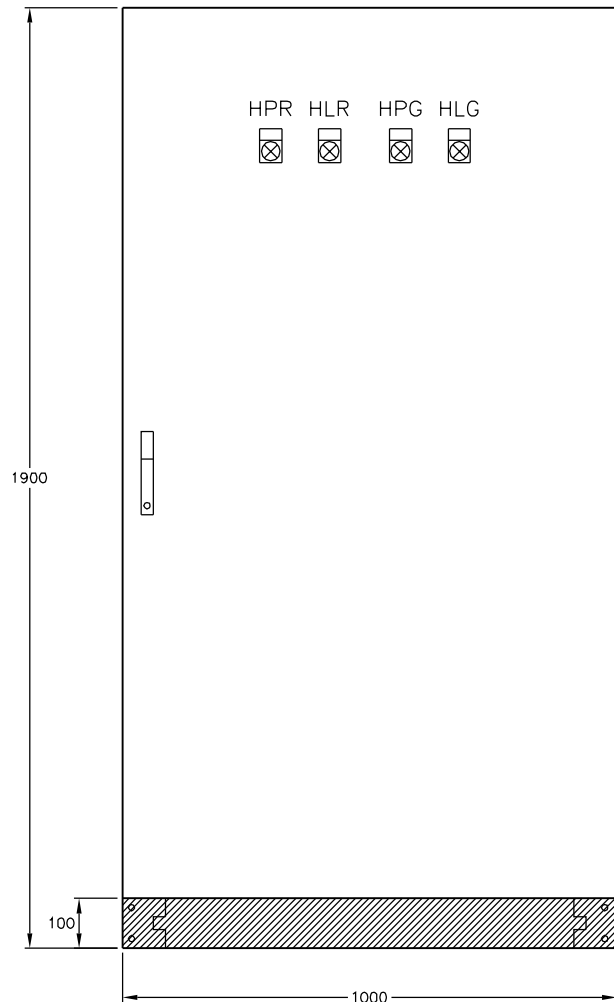

DESCRIZIONE

- HPR SPIA BIANCA PRESENZA TENSIONE RETE
- HLR SPIA VERDE RETE IN UTILIZZO
- HPG SPIA GIALLA PRESENZA TENSIONE GRUPPO
- HLG SPIA BLU GRUPPO IN UTILIZZO

DESCRIPTION

- HPR MAINS VOLTAGE PRESENCE WHITE LAMP
- HLR MAINS ON LOAD GREEN LAMP
- HPG GENSET VOLTAGE PRESENCE YELLOW LAMP
- HLG GENSET ON LOAD BLUE LAMP

		IMPIANTO Q.E. COMMUTAZIONE RETE/GE		TITOLO DESCRIZIONE MORSETTIERE		DISEGNATORE AB		N. DIS. COMM.DWG N. ARCH.		FOGLIO 4	SEGUE 5
REV.		DATA		OGGETTO MODIFICA		FIRMA		DATA 21/12/2006		TOT. FOGLI 5	
		GREEN POWER SYSTEMS Srl		SCHEMA COMM		RIF. CLIENTE		SCALA			

A
B
C
D
E
F
G
H
I
J
K
L

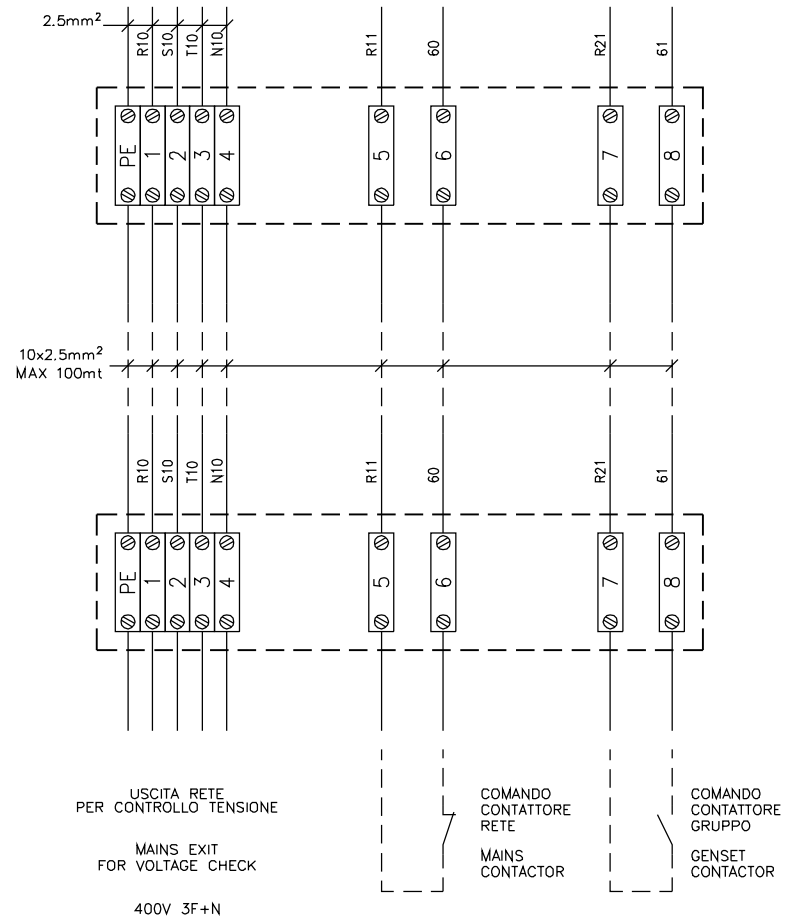
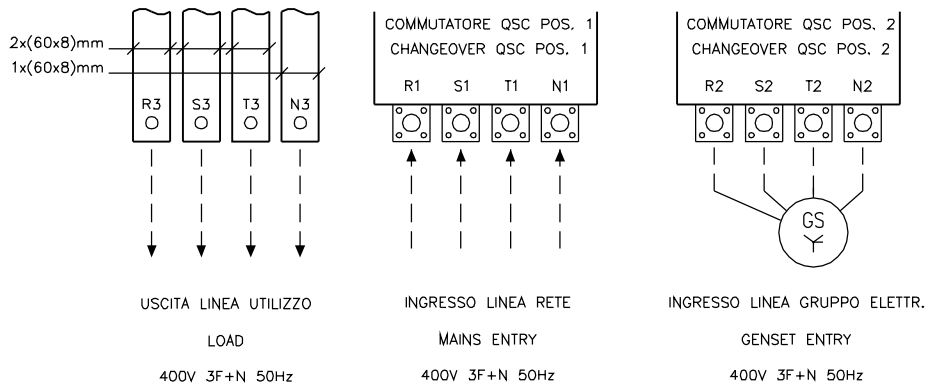

REV.	DATA	OGGETTO MODIFICA	FIRMA	IMPIANTO Q.E. COMMUTAZIONE RETE/GE GREEN POWER SYSTEMS Srl	TITOLO DESCRIZIONE MORSETTIERE SCHEMA COMM	RIF. CLIENTE	DISEGNATORE AB FIRMA	N. DIS. COMM.DWG N. ARCH. DATA 21/12/2006 SCALA	FOGLIO 5 TOT. FOGLI 5	SEGUE EL.COM.
------	------	------------------	-------	--	---	--------------	----------------------------	--	--------------------------------	------------------