

<b>Electrical Characteristics</b>										
Frequency	Hz	50				60				
Voltage (star)	V	380	400	415	440	415	440	460	480	
Rated power class H	kVA	20	20	20	18	21	23	24	24	
	kW	16	16	16	14,4	16,8	18	19,2	19,2	
Rated power class F	kVA	18,5	18,5	18,5	17	19	20	22	22	
	kW	15	15	15	13,6	15,2	16	17,6	17,6	
Regulation with SR7/2		±1,5 % with any power factor and speed variations between -5% +30%								
Insulation class		H								
Execution		Brushless								
Stator winding		12 ends								
Rotor		without damping cage								
Efficiencies class H	4/4	%	87,5	87,6	87,3	87,1	89	89,5	89,6	89,7
(see graph. for details)	3/4	%	87,7	88	87,7	87,6	89,1	89,3	89,5	89,7
	2/4	%	85,7	85,8	85,8	85,7	87,4	87,5	87,6	87,7
	1/4	%	83,3	83,2	83	82,5	85,3	85,3	85,3	85,2
Reactances (f. l.cl. F)	Xd	%	193,9	175	162,6	130,2	204,8	199,6	190,5	175
	Xd'	%	18,28	16,5	15,33	12,27	19,31	18,82	17,97	16,5
	Xd''	%	10,42	9,4	8,73	6,99	11,00	10,72	10,24	9,4
	Xq	%	84,2	76	70,6	56,5	89,0	86,7	82,8	76
	Xq'	%	84,2	76	70,6	56,5	89,0	86,7	82,8	76
	Xq''	%	23,3	21	19,5	15,6	24,6	24,0	22,9	21
	X <sub>2</sub>	%	15,73	14,2	13,19	10,56	16,62	16,20	15,46	14,2
	X <sub>0</sub>	%	3,55	3,2	2,97	2,38	3,75	3,65	3,48	3,2
Short Circuit Ratio	Kcc		0,53	0,65	0,87	1,45	0,41	0,48	0,53	0,65
Time Constants	Td'	sec.	0,045							
	Td''	sec.	0,015							
	Tdo'	sec.	0,87							
	Tα	sec.	0,013							
Short Circuit Current Capacity		%	>300				>320			
Excitation at no load	Amp.		0,4	0,5	0,6	0,8	0,3	0,35	0,4	0,5
Excitation at full load	Amp.		1,4	1,5	1,7	1,9	1,2	1,3	1,4	1,5
Overload (long-term)		%	1 hour in a 6 hours period 110% rated load							
Overload per 20 sec.		%	300							
Stator Winding Resistance (20°C)	Ω		0,389							
Rotor Winding Resistance (20°C)	Ω		1,537							
Exciter Resistance (20 °C)	Ω		Rotor : 0,64				Stator : 10,60			
Heat dissipation at f.l.cl. H	W		2286	2265	2328	2133	2076	2159	2229	2205
Telephone Interference			THF < 2%				TIF < 45			
Radio interference			EN50081-1, EN50082-1, VDE0875K. For others standards apply to factory							
Waveform Distors.(THD) at f. load	LL/LN %		2 / 2							
Waveform Distors.(THD) at no load	LL/LN %		3,6 / 3,5							
<b>Mechanical characteristics</b>										
Protection			IP 23 (other protection on request)							
DE bearing			6309-2RS							
NDE bearing			6209-2RS							
Weight of wound stator assembly	kg		44							
Weight of wound rotor assembly	kg		23							
Weight of complete generator	kg		133							
Maximun overspeed	rpm		2250							
Unbalanced magnetic pull at f.l.cl.F	kN/mm		3,8							
Cooling air requirement	m <sup>3</sup> /min		5,3				5,8			
Inertia Constant (H)	sec.		0,078				0,094			
Noise level at 1m/7m	dB(A)		68 / 57				71 / 61			

All technical data are to be considered as a reference and they can be modified without any notice.

This document is a propriety of Mecc Alte S.p.a..All rights reserved.

**50 Hz**

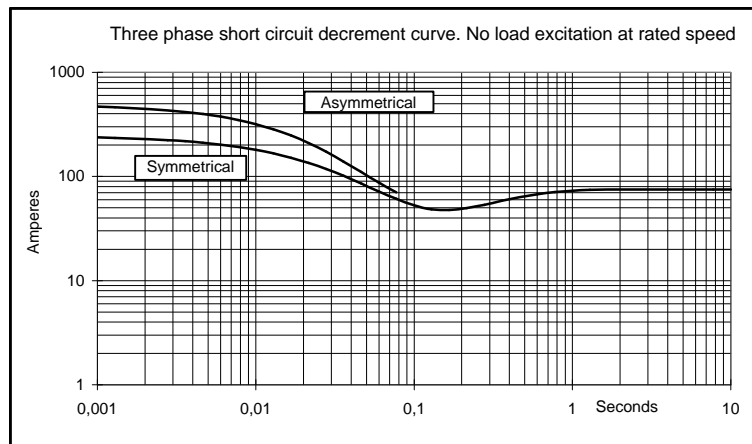
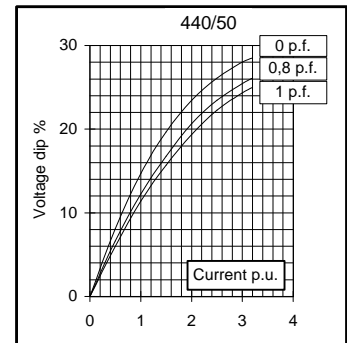
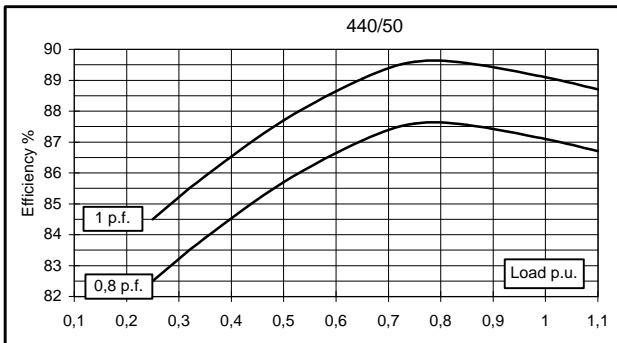
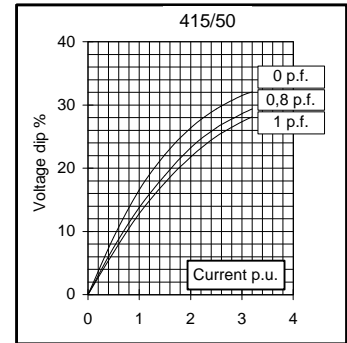
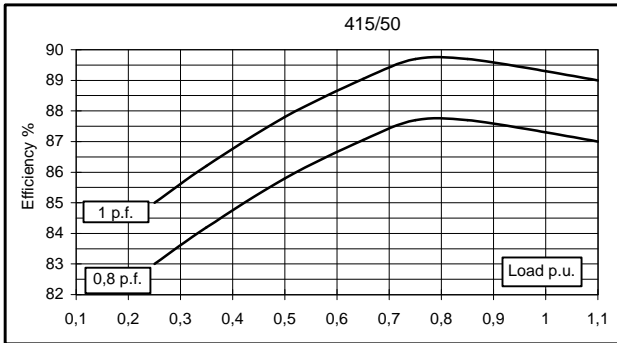
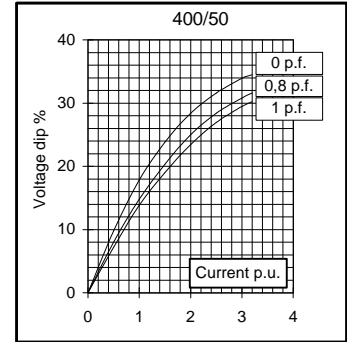
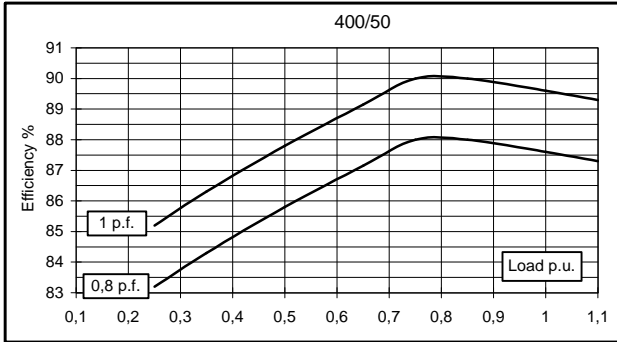
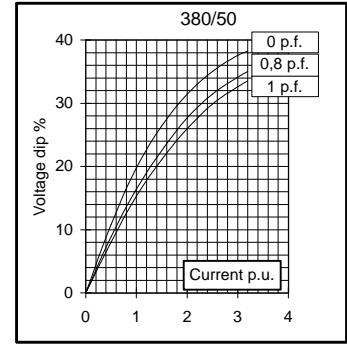
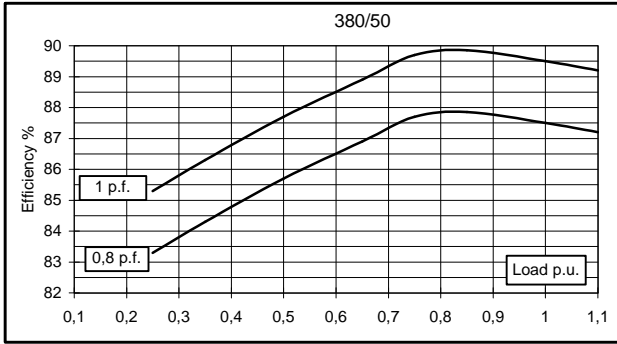

**60 Hz**

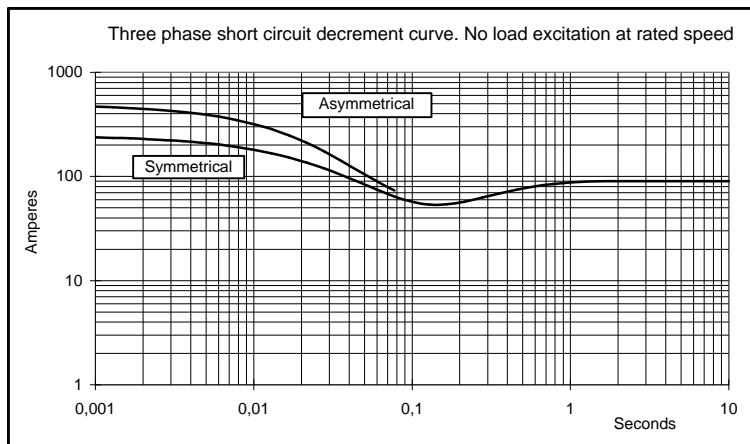
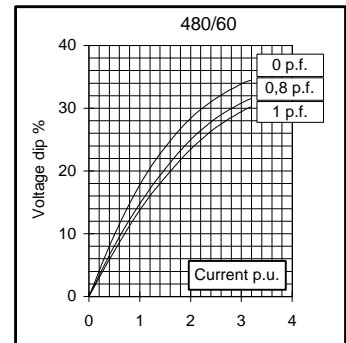
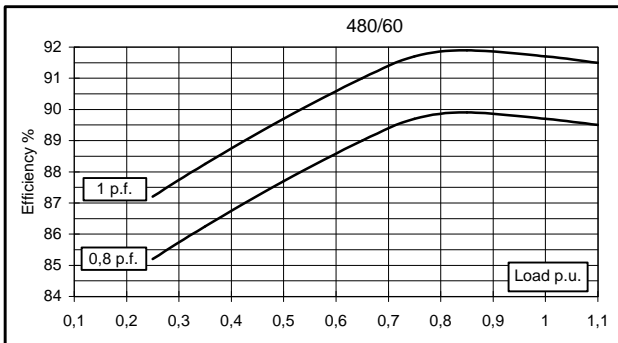
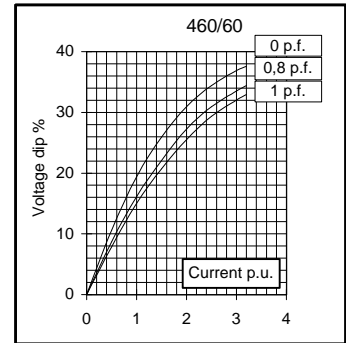
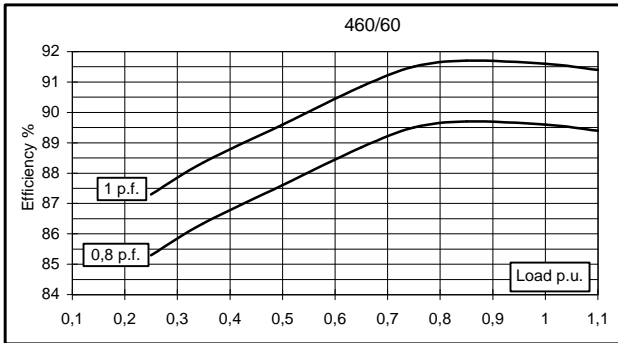
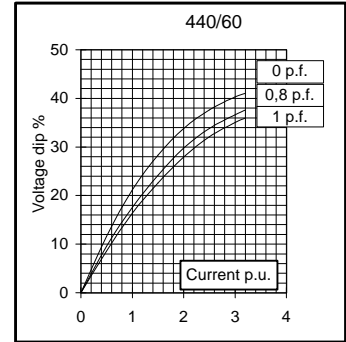
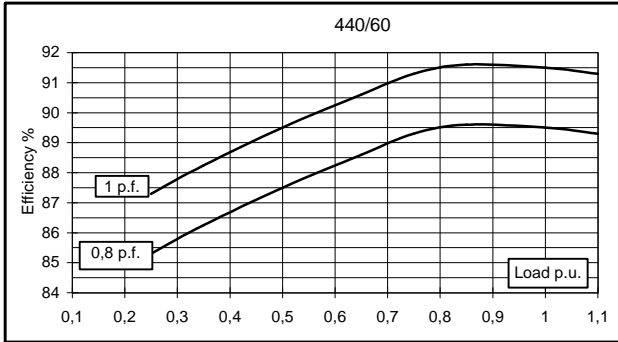
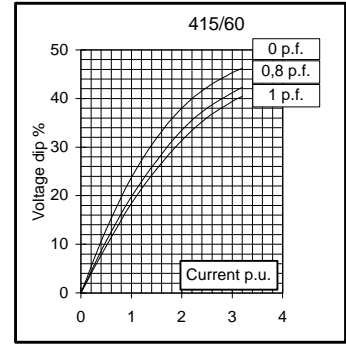
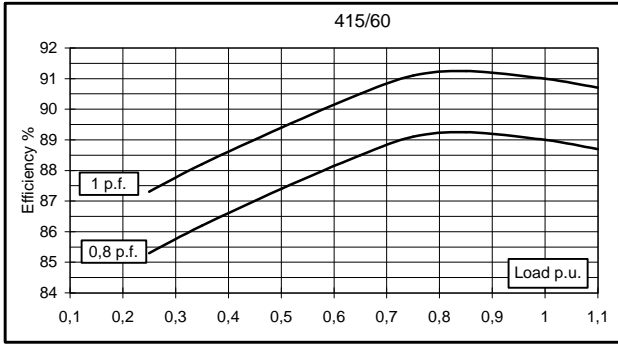

## TWO BEARING MOMENTS OF INERTIA

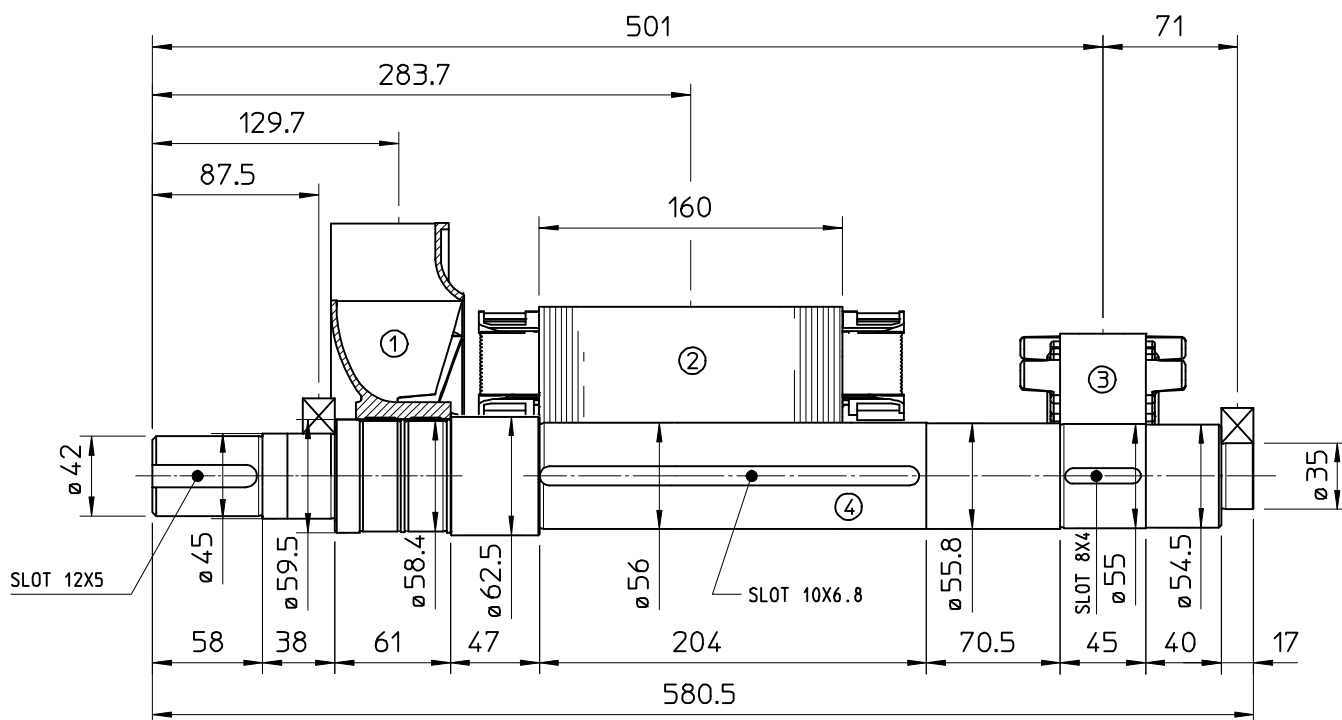

COMPONENT	WEIGHT Kg	J Kg <sup>m</sup> <sup>2</sup>
1 FAN	1.2	0.0102
2 MAIN ROTOR	22.9	0.10
3 EX ROTOR	5.4	0.012
4 SHAFT	10.6	0.004
6 TOTAL	40.1	0.1262

## TWO BEARING DIMENSIONS

