

Electrical Characteristics										
Frequency	Hz	50				60				
Voltage (star)	V	380	400	415	440	415	440	460	480	
Rated power class H	kVA	16	16	16	14,5	16,5	17,5	19,2	19,2	
	kW	12,8	12,8	12,8	11,6	13,2	14	15,4	15,4	
Rated power class F	kVA	15	15	15	13,6	15,5	16,5	18	18	
	kW	12	12	12	10,9	12,4	13,2	14,4	14,4	
Regulation with SR7/2		±1,5 % with any power factor and speed variations between -5% +30%								
Insulation class		H								
Execution		Brushless								
Stator winding		12 ends								
Rotor		without damping cage								
Efficiencies class H	4/4	%	87,2	87,3	87	86,8	88,1	88,6	88,7	88,8
(see graph. for details)	3/4	%	87,2	87,5	87,4	87,1	88,1	88,3	88,5	88,7
	2/4	%	85,4	85,5	85,5	85,2	86	86,1	86,2	86,3
	1/4	%	83,3	83,2	83	82,5	83,4	83,2	83,3	83,6
Reactances (f. l.cl. F)	Xd	%	217,2	196	182,1	146,8	225,3	212,6	213,4	196
	Xd'	%	18,73	16,9	15,70	12,66	19,43	18,33	18,40	16,9
	Xd"	%	12,74	11,5	10,68	8,61	13,22	12,47	12,52	11,5
	Xq	%	79,8	72	66,9	53,9	82,8	78,1	78,4	72
	Xq'	%	79,8	72	66,9	53,9	82,8	78,1	78,4	72
	Xq"	%	26,6	24	22,3	18,0	27,6	26,0	26,1	24
	X ₂	%	18,84	17	15,79	12,73	19,54	18,44	18,51	17
	X ₀	%	3,99	3,6	3,34	2,70	4,14	3,90	3,92	3,6
Short Circuit Ratio	Kcc		0,55	0,67	0,88	1,50	0,42	0,50	0,55	0,67
Time Constants	Td'	sec.	0,051							
	Td"	sec.	0,018							
	Tdo'	sec.	0,90							
	Tα	sec.	0,016							
Short Circuit Current Capacity		%	>300				>320			
Excitation at no load	Amp.		0,4	0,5	0,6	0,9	0,25	0,32	0,35	0,4
Excitation at full load	Amp.		1,7	1,7	1,9	2,1	1,3	1,5	1,6	1,7
Overload (long-term)		%	1 hour in a 6 hours period 110% rated load							
Overload per 20 sec.		%	300							
Stator Winding Resistance (20°C)	Ω		0,424							
Rotor Winding Resistance (20°C)	Ω		1,26							
Exciter Resistance (20 °C)	Ω		Rotor : 0,640				Stator : 10,60			
Heat dissipation at f.l.cl.H	W		1879	1862	1913	1764	1783	1801	1957	1937
Telephone Interference			THF < 2 %				TIF < 45			
Radio interference			EN50081-1, EN50082-1, VDE 0875K.For others standards apply to factory							
Waveform Distors.(THD) at f. load	LL/LN %		2 / 2							
Waveform Distors.(THD) at no load	LL/LN %		3,7 / 3,7							
Mechanical characteristics										
Protection			IP 23 (other protection on request)							
DE bearing			6309-2RS							
NDE bearing			6209-2RS							
Weight of wound stator assembly	kg		33,2							
Weight of wound rotor assembly	kg		18							
Weight of complete generator	kg		108							
Maximun overspeed	rpm		2250							
Unbalanced magnetic pull at f.l.cl.F	kN/mm		3							
Cooling air requirement	m ³ /min		5,3				5,8			
Inertia Constant (H)	sec.		0,08				0,096			
Noise level at 1m/7m	dB(A)		68 / 57				71 / 61			

50 Hz

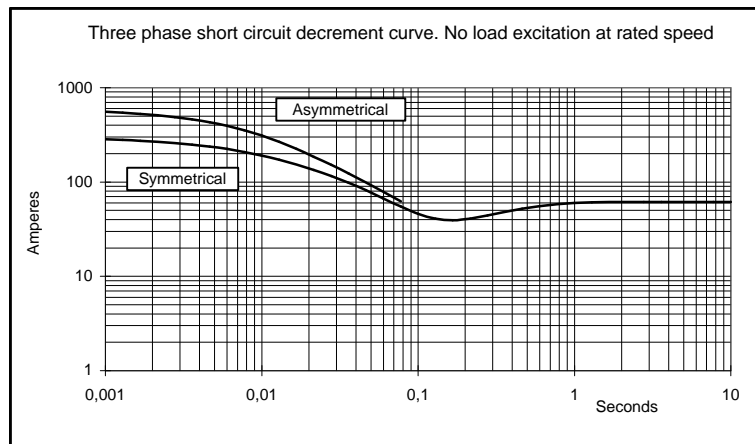

60 Hz

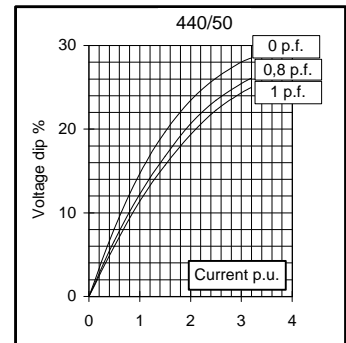
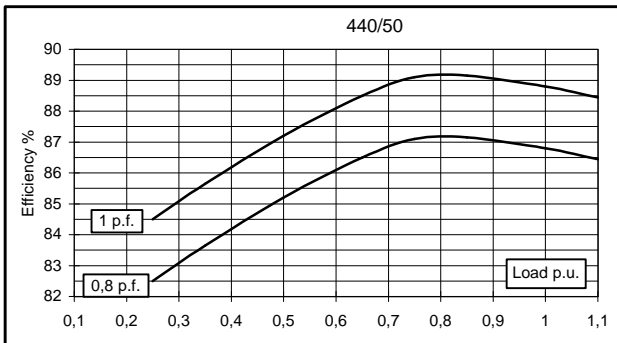
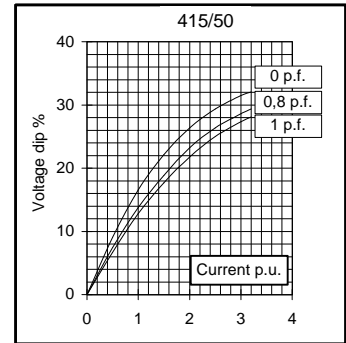
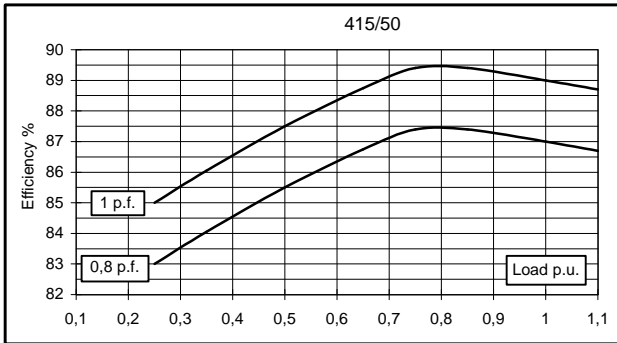
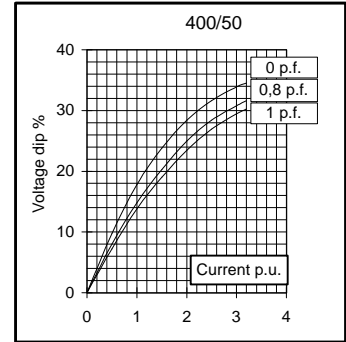
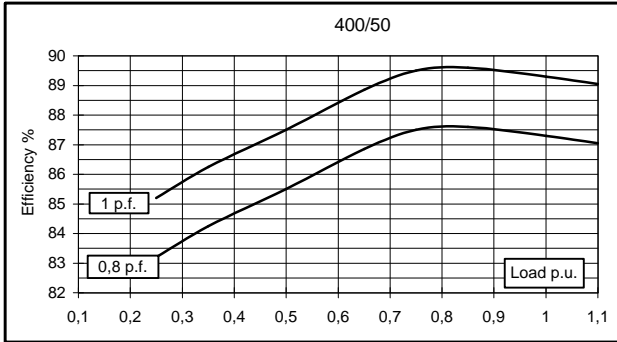
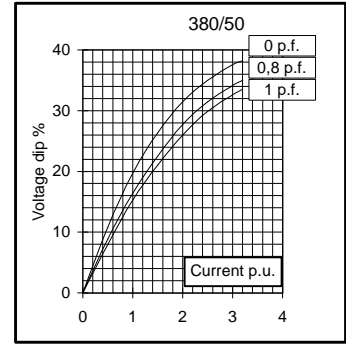
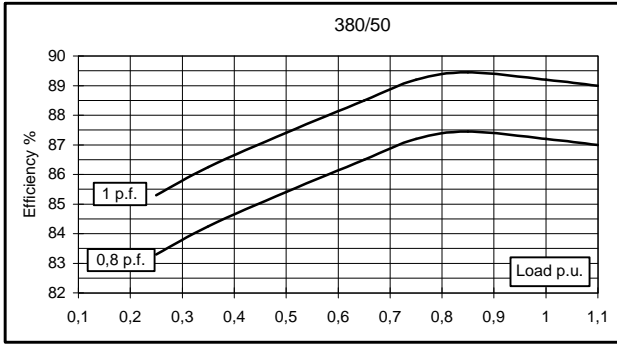
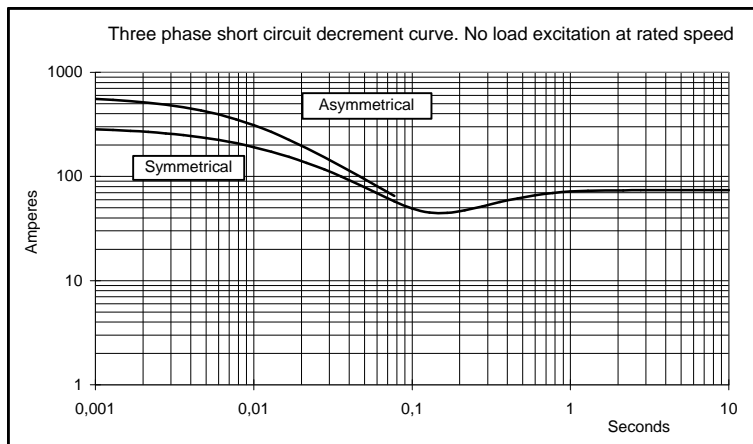
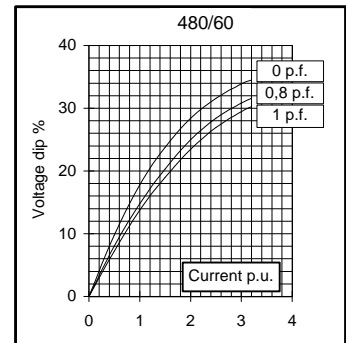
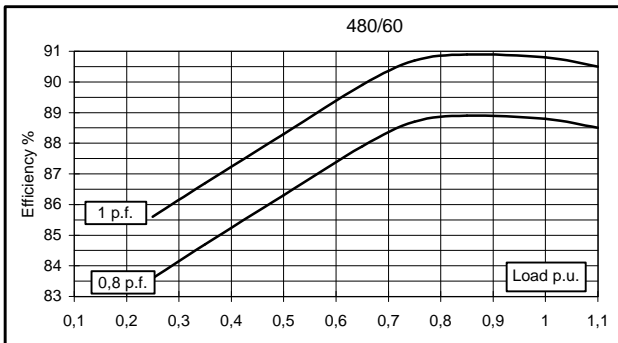
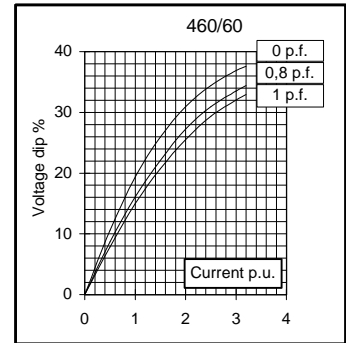
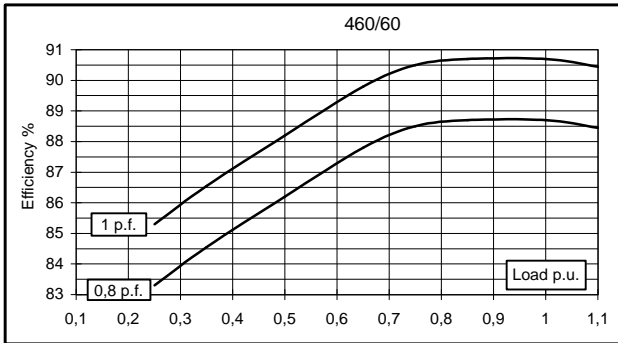
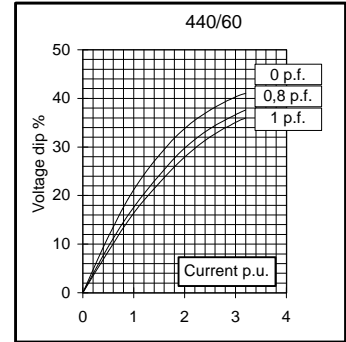
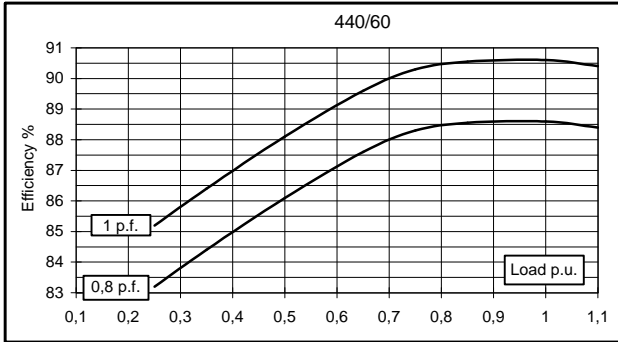
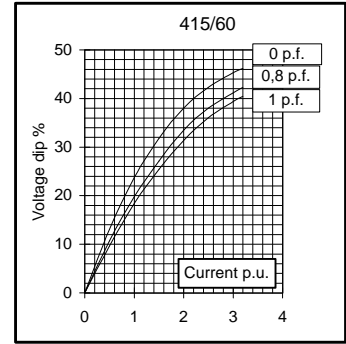
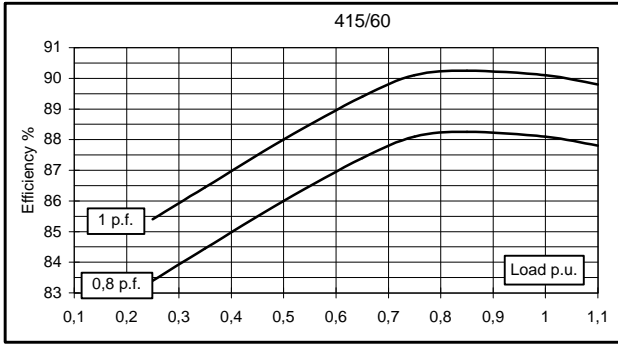

TWO BEARING MOMENTS OF INERTIA

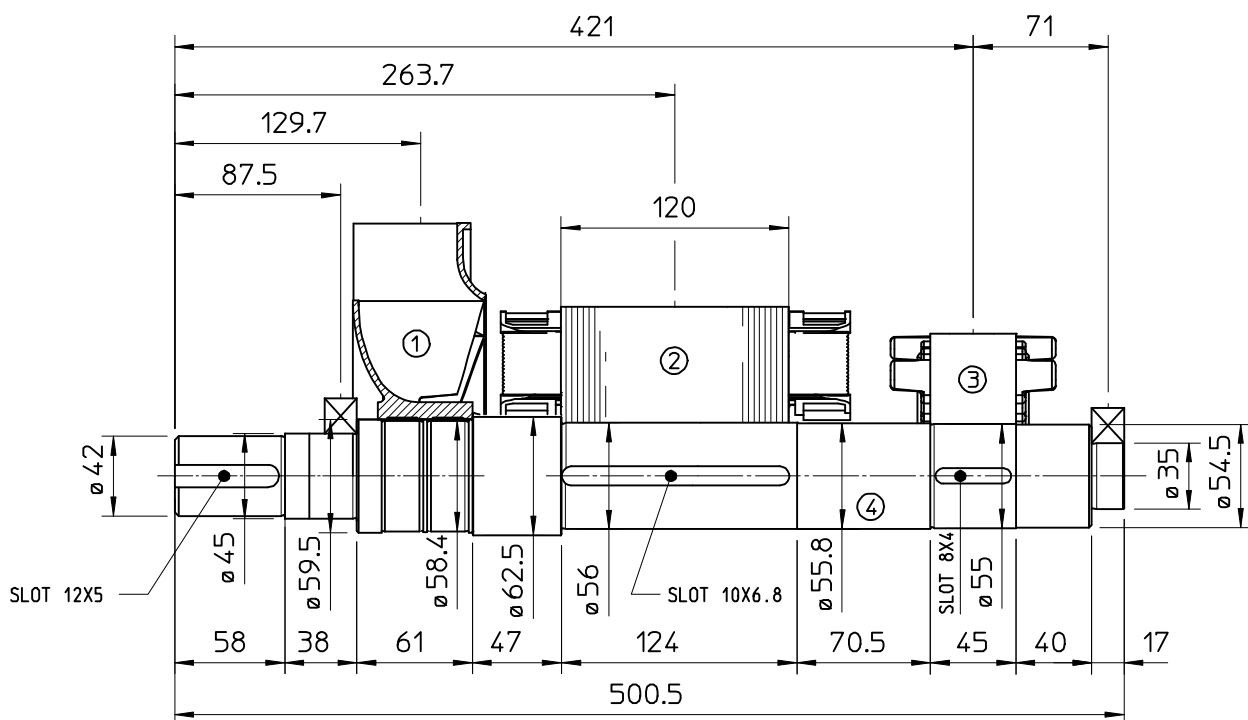

COMPONENT	WEIGHT Kg	J Kg ^m ²
1 FAN	1.2	0.0102
2 MAIN ROTOR	18	0.078
3 EX ROTOR	5.4	0.012
4 SHAFT	8.8	0.0035
6 TOTAL	33.4	0.1037

TWO BEARING DIMENSIONS

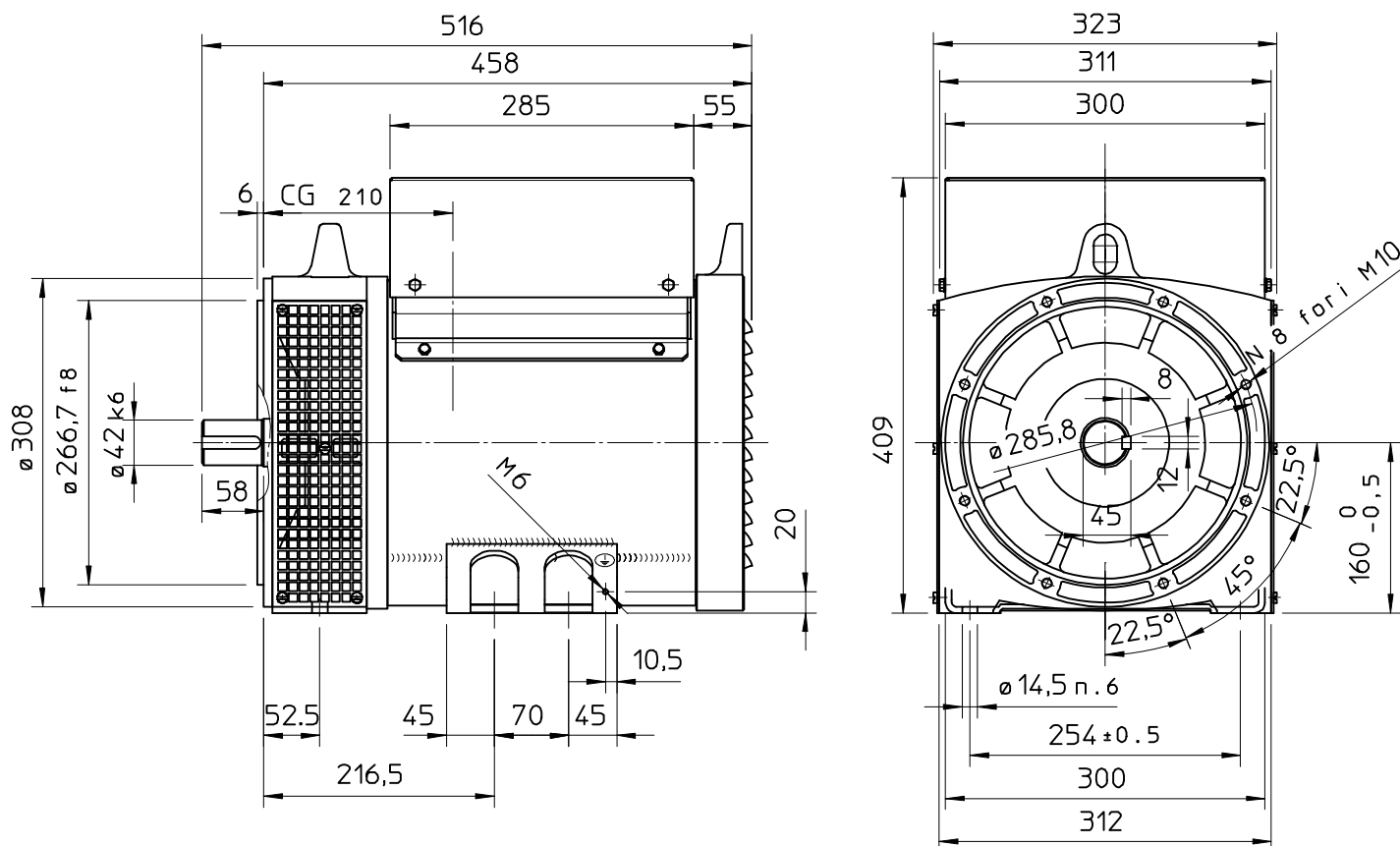

C.G. = GRAVITY CENTER

