

Electrical Characteristics										
Frequency	Hz	50				60				
Voltage (star)	V	380	400	415	440	415	440	460	480	
Rated power class H	kVA	82	82	80	67	84	93	98,5	98,5	
	kW	65,6	65,6	64	53,6	67,2	74,4	78,8	78,8	
Rated power class F	kVA	75	75	73	61	76	85	90	90	
	kW	60	60	58,4	48,8	60,8	68	72	72	
Regulation with SR7/2		±1,5 % with any power factor and speed variations between -5% +30%								
Insulation class		H								
Execution		Brushless								
Stator winding		12 ends								
Rotor		with damping cage								
Efficiencies class H	4/4	%	88,9	89	88,7	88,5	89,8	90,3	90,4	90,5
(see graph. for details)	3/4	%	89,1	89,4	89,3	89	90,2	90,4	90,6	90,8
	2/4	%	86,4	86,5	86,5	86,2	86,9	87	87,1	87,2
	1/4	%	80,1	80	79,8	79,3	80,8	80,6	80,7	81
Reactances (f. l.cl. F)	Xd	%	574,0	518	469,5	349,8	591,0	582,0	564,0	518
	Xd'	%	13,35	12,05	10,92	8,14	13,75	13,54	13,12	12,05
	Xd''	%	6,04	5,45	4,94	3,68	6,22	6,12	5,93	5,45
	Xq	%	284,8	257	232,9	173,5	293,2	288,8	279,8	257
	Xq'	%	284,8	257	232,9	173,5	293,2	288,8	279,8	257
	Xq''	%	21,9	19,8	17,9	13,4	22,6	22,2	21,6	19,8
	X ₂	%	18,95	17,1	15,50	11,55	19,51	19,21	18,62	17,1
	X ₀	%	3,10	2,8	2,54	1,89	3,19	3,15	3,05	2,8
Short Circuit Ratio	Kcc		0,45	0,57	0,67	1,27	0,32	0,37	0,45	0,57
Time Constants	Td'	sec.	0,075							
	Td''	sec.	0,016							
	Tdo'	sec.	1,40							
	Tα	sec.	0,016							
Short Circuit Current Capacity		%	>300				>320			
Excitation at no load	Amp.		0,5	0,6	0,7	0,85	0,3	0,4	0,45	0,5
Excitation at full load	Amp.		1,6	1,7	1,8	1,9	1,3	1,4	1,5	1,6
Overload (long-term)		%	1 hour in a 6 hours period 110% rated load							
Overload per 20 sec.		%	300							
Stator Winding Resistance (20°C)	Ω		0,034							
Rotor Winding Resistance (20°C)	Ω		4,68							
Exciter Resistance (20 °C)	Ω		Rotor : 0,442				Stator : 11,35			
Heat dissipation at f.l.cl.H	W		8191	8108	8153	6965	7633	7992	8368	8272
Telephone Interference			THF < 2%				TIF < 50			
Radio interference			EN50081-1, EN50082-1, VDE0875K. For others standards apply to factory							
Waveform Distors.(THD) at f. load	LL/LN %		3,3 / 2,9							
Waveform Distors.(THD) at no load	LL/LN %		4,5 / 4							
Mechanical characteristics										
Protection			IP 21 (other protection on request)							
DE bearing			6312-2RS							
NDE bearing			6309-2RS							
Weight of wound stator assembly	kg		79,5							
Weight of wound rotor assembly	kg		53,6							
Weight of complete generator	kg		236							
Maximun overspeed	rpm		4320							
Unbalanced magnetic pull at f.l.cl.F	kN/mm		4,1							
Cooling air requirement	m³/min		22,4				27			
Inertia Constant (H)	sec.		0,312				0,374			
Noise level at 1m/7m	dB(A)		88 / 77				93 / 80			

50 Hz

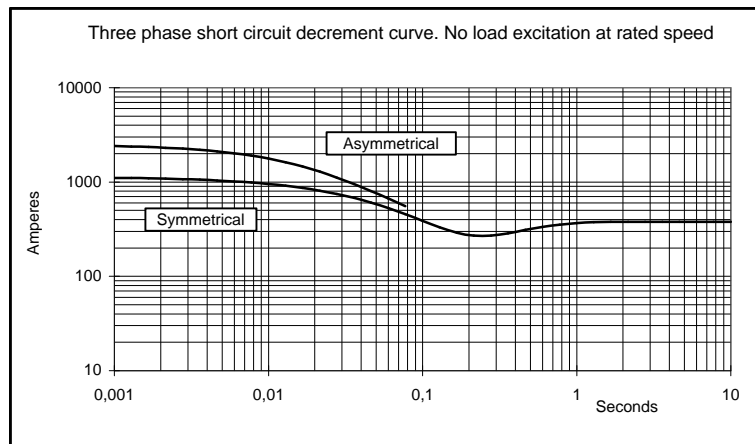

60 Hz

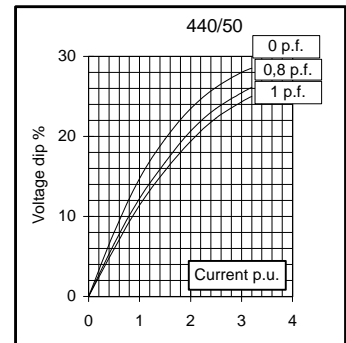
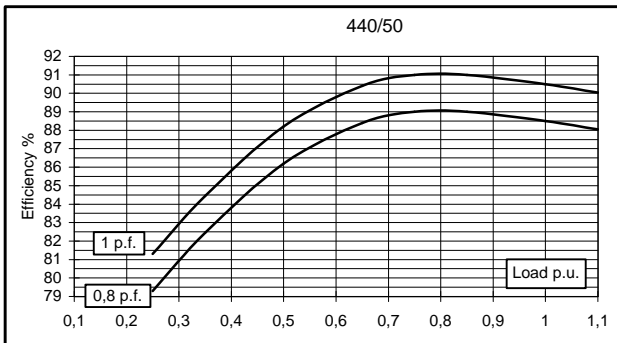
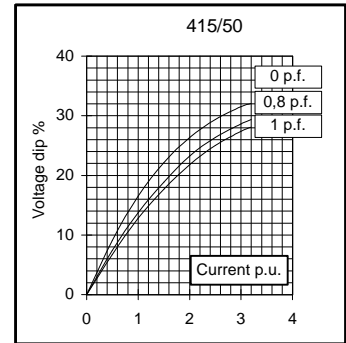
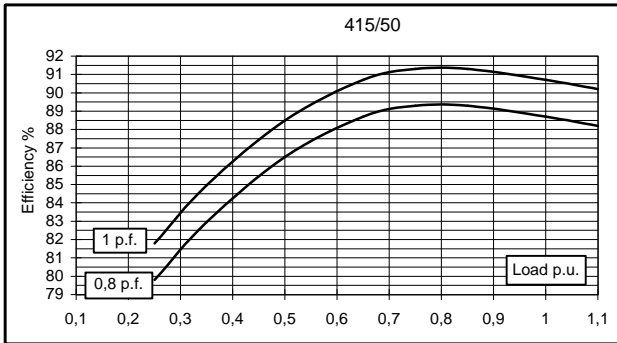
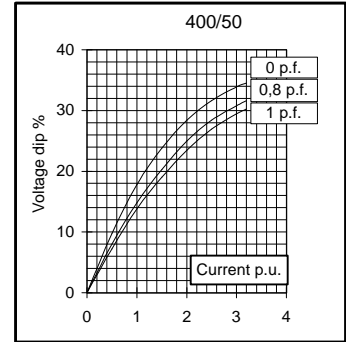
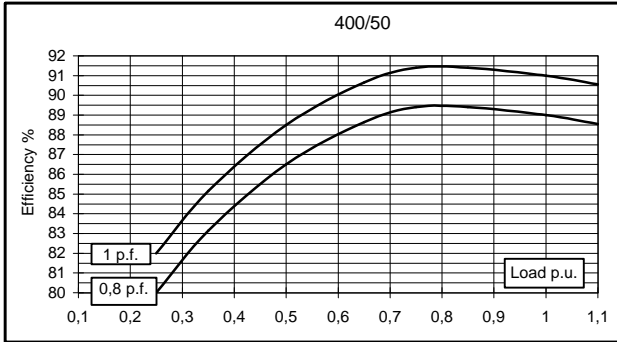
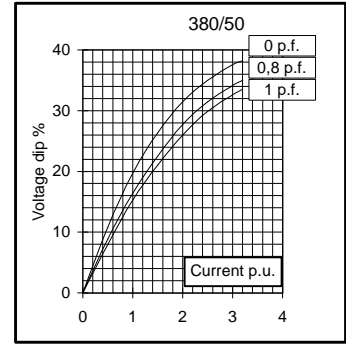
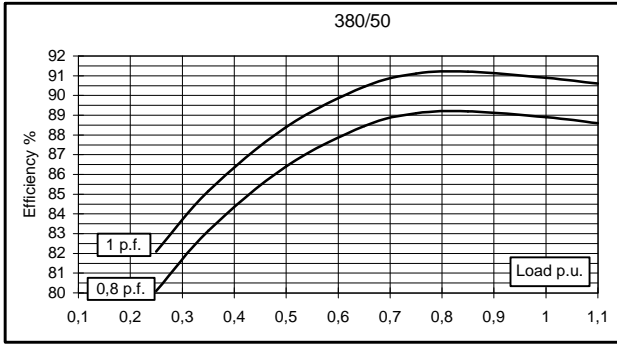
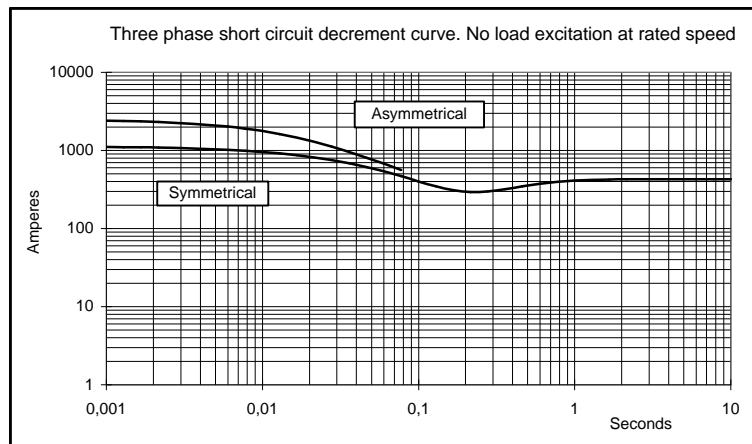
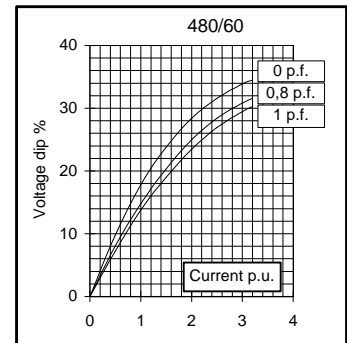
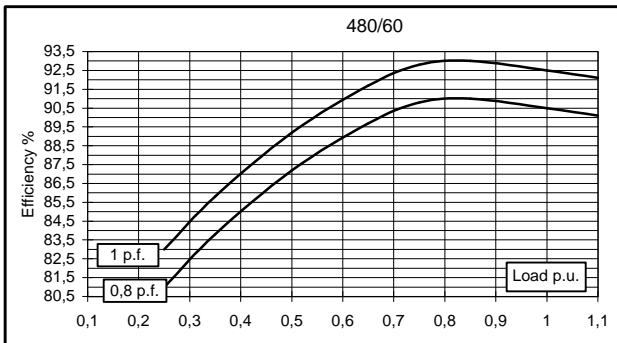
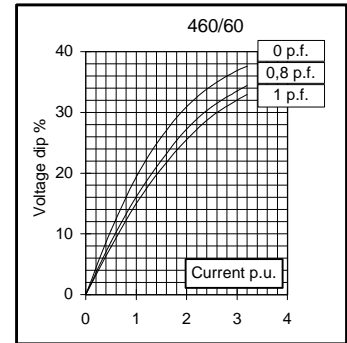
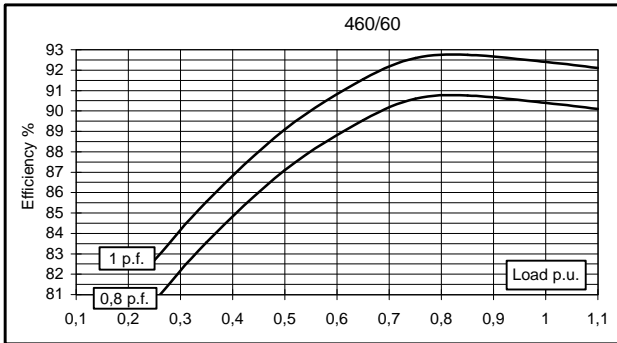
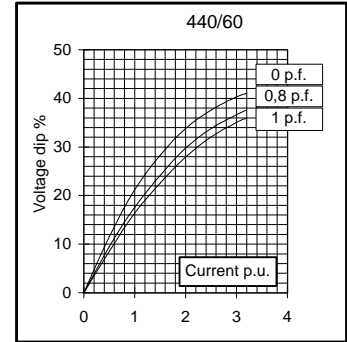
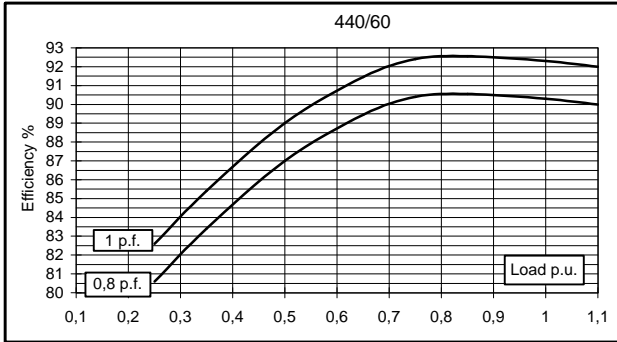
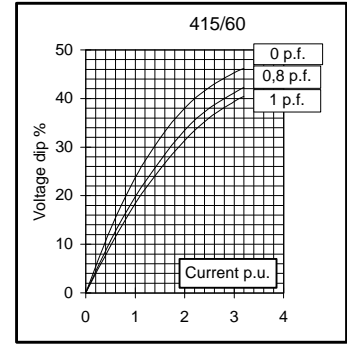
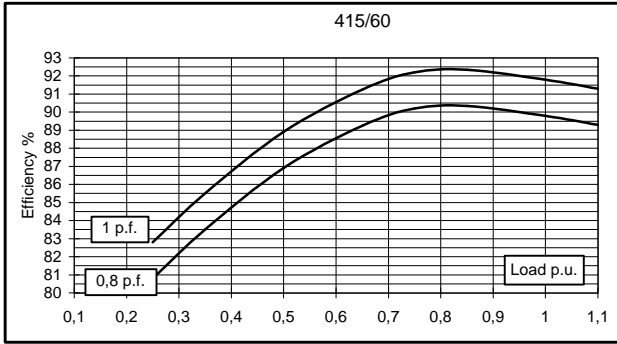

TWO BEARING MOMENTS OF INERTIA

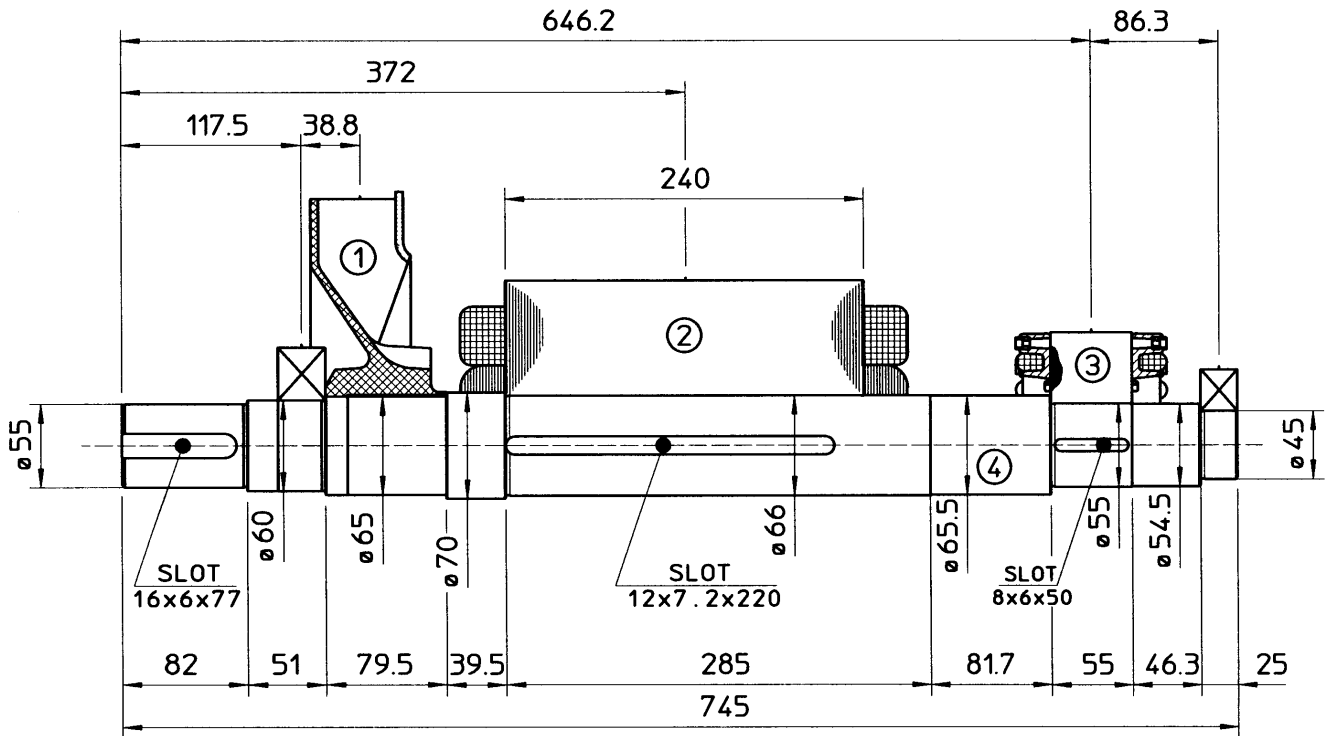

COMPONENT	WEIGHT kg	J kgm ²
1 FAN	2.3	0.0224
2 MAIN ROTOR	52	0.195
3 EX. ROTOR	7	0.016
4 SHAFT	17.5	0.008
TOTAL	78.8	0.2414

TWO BEARING DIMENSIONS

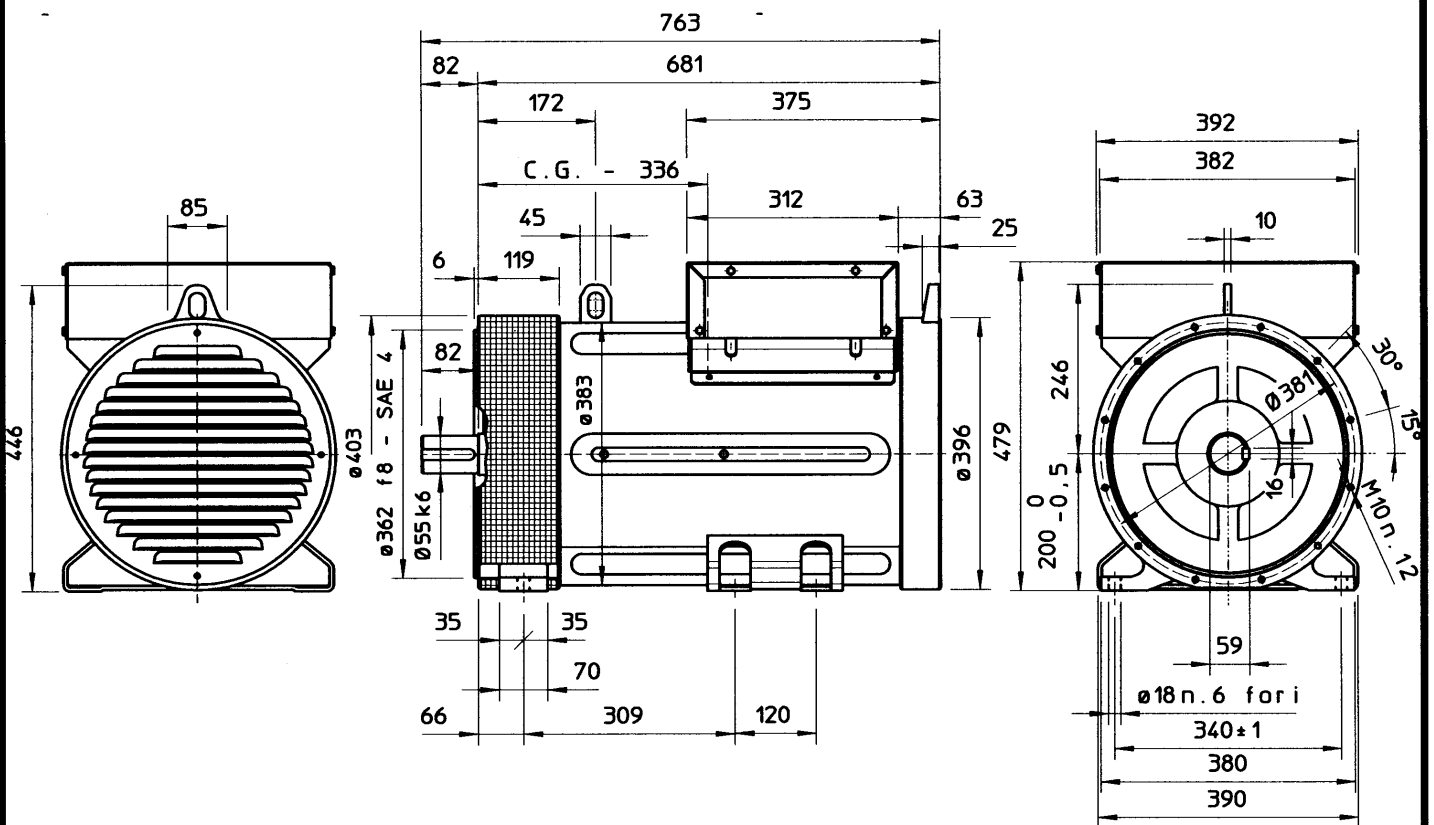

C.G. - GRAVITY CENTER

SINGLE BEARING MOMENTS OF INERTIA

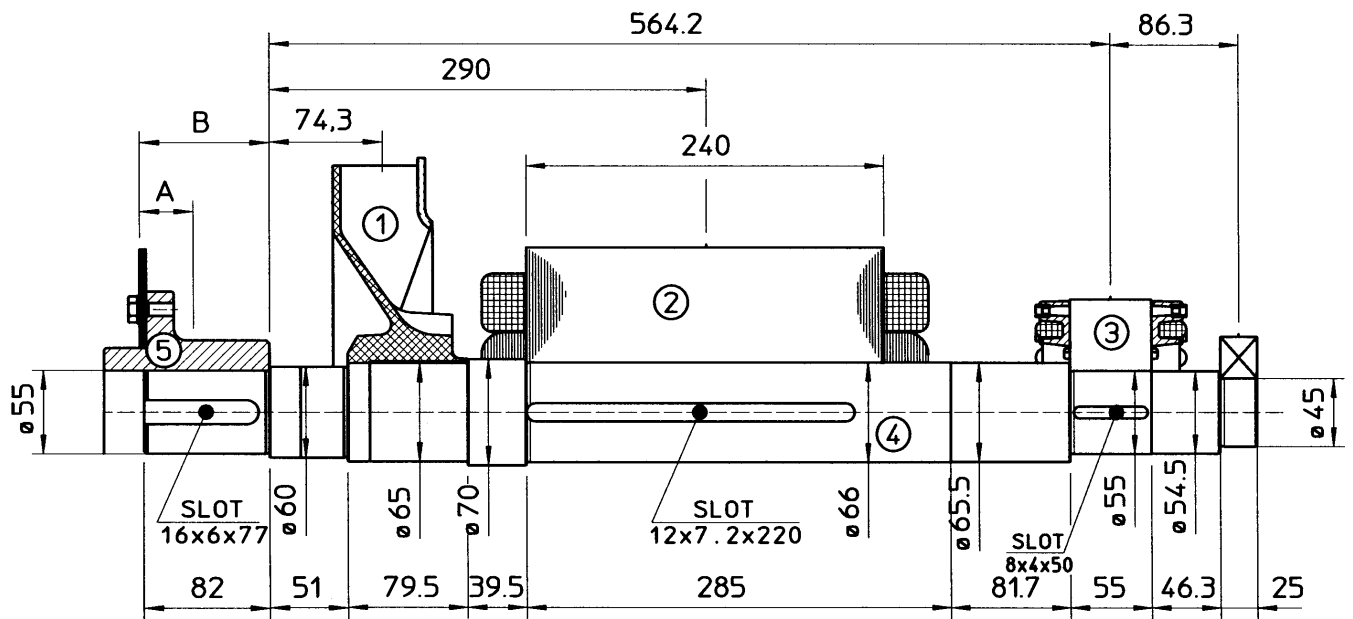

COMPONENT	WEIGHT kg	J kgm ²
1 FAN	2.3	0.0224
2 MAIN ROTOR	52	0.195
3 EX. ROTOR	7	0.016
4 SHAFT	17.5	0.008
TOTAL	78.8	0.2414

SAE No	SHAFTS COUPLING FLEX PLATE			
	A	B	WEIGHT kg	J kgm ²
6.5	26.1	75.2	4.2	0.0225
7.5	25.7	75.2	4.4	0.0256
8	38.25	106.9	7.2	0.0314
10	32.7	98.7	8.7	0.0485
11.5	24	84.5	8.3	0.0372

SINGLE BEARING DIMENSIONS

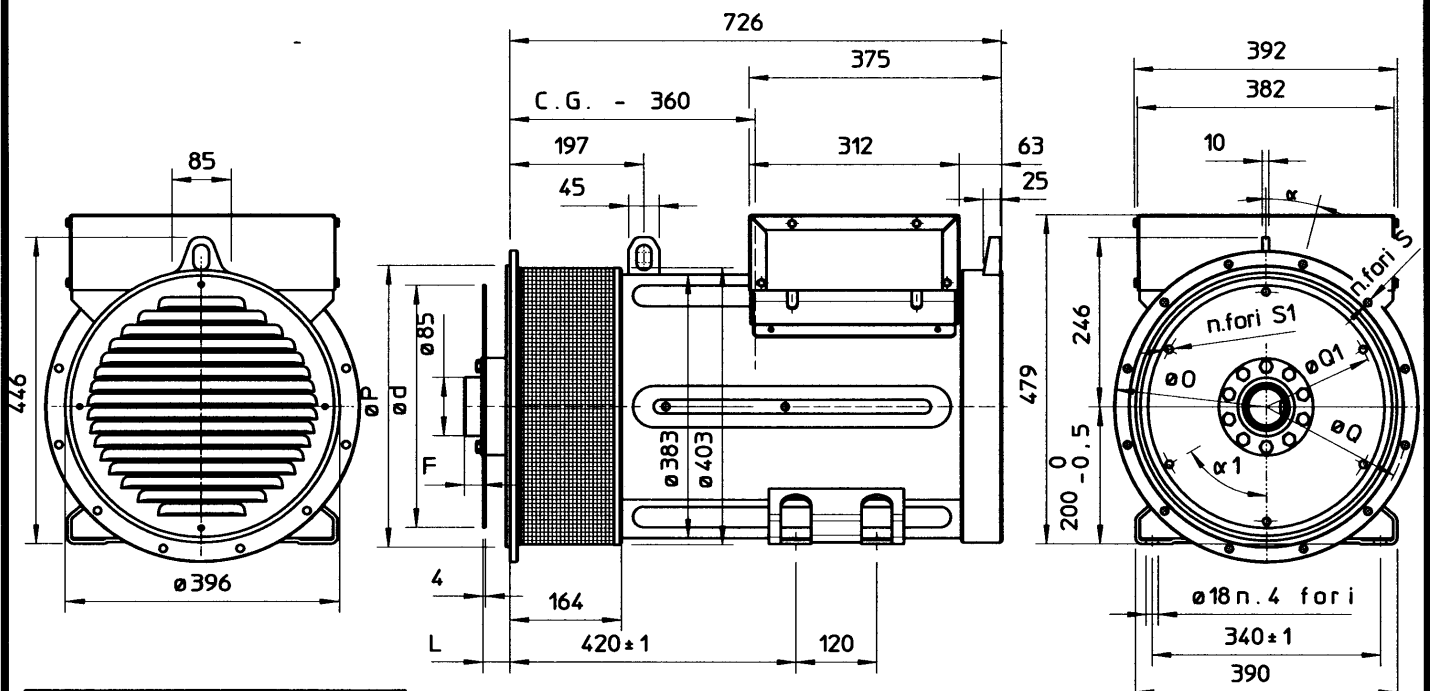

SAE N.	GIUNTI A DISCHI DISC COUPLING DISQUE DE MONOPALIER SCHEIBENKUPPLUNG						
	L	d	Q1	N. FORI	S1	α1	F
6 1/2	30.2	215.9	200	6	9	60°	7
7 1/2	30.2	241.3	222.25	8	9	45°	7
8	62	263.52	244.47	6	11	60°	2
10	53.8	314.32	295.27	8	11	45°	10
11 1/2	39.6	352.42	333.37	8	11	45°	24

SAE N.	FLANGIA / FLANGE BRIDE / FLANSCH					
	O	P	Q	N. FORI	S	α
5	356	314.3	333.4	8	11	22°30'
4	403	362	381	12	11	15°
3	451	409.6	428.6	12	11	15°
2	489	447.7	466.7	12	11	15°
1	552	511.2	530.2	12	11	15°

C.G. - GRAVITY CENTER