

<b>Electrical Characteristics</b>										
Frequency	Hz	50				60				
Voltage (star)	V	380	400	415	440	415	440	460	480	
Rated power class H	kVA	55	55	55	47	58	64	66	66	
	kW	44	44	44	37,6	46,4	51,2	52,8	52,8	
Rated power class F	kVA	50	50	50	42,5	52,5	58	60	60	
	kW	40	40	40	34	42	46,4	48	48	
Regulation with	SR7/2	±1,5 % with any power factor and speed variations between -5% +30%								
Insulation class		H								
Execution		Brushless								
Stator winding		12 ends								
Rotor		with damping cage								
Efficiencies class H (see graph. for details)	4/4	%	88	88,1	87,8	87,6	88,8	89,3	89,4	89,5
	3/4	%	88,2	88,5	88,4	88,1	89,1	89,3	89,5	89,7
	2/4	%	85,3	85,4	85,4	85,1	86,5	86,6	86,7	86,8
	1/4	%	81,1	81	80,8	80,3	81,8	81,6	81,7	82
Reactances (f. l.cl. F)	Xd	%	487,5	440	408,8	310,7	517,3	507,8	479,1	440
	Xd'	%	13,74	12,4	11,52	8,76	14,58	14,31	13,50	12,4
	Xd''	%	6,76	6,1	5,67	4,31	7,17	7,04	6,64	6,1
	Xq	%	259,3	234	217,4	165,3	275,1	270,0	254,8	234
	Xq'	%	259,3	234	217,4	165,3	275,1	270,0	254,8	234
	Xq''	%	28,1	25,4	23,6	17,9	29,9	29,3	27,7	25,4
	X <sub>2</sub>	%	18,73	16,9	15,70	11,94	19,87	19,50	18,40	16,9
	X <sub>0</sub>	%	3,55	3,2	2,97	2,26	3,76	3,69	3,48	3,2
Short Circuit Ratio	Kcc		0,41	0,51	0,61	1,01	0,21	0,31	0,41	0,51
Time Constants	Td'	sec.	0,072							
	Td''	sec.	0,013							
	Tdo'	sec.	1,30							
	Tα	sec.	0,011							
Short Circuit Current Capacity	%	>300				>320				
Excitation at no load	Amp.	0,5	0,6	0,7	0,85	0,35	0,4	0,5	0,6	
Excitation at full load	Amp.	1,8	2	2,1	2,2	1,5	1,6	1,8	1,9	
Overload (long-term)	%	1 hour in a 6 hours period 110% rated load								
Overload per 20 sec.	%	300								
Stator Winding Resistance (20°C)	Ω	0,046								
Rotor Winding Resistance (20°C)	Ω	4,071								
Exciter Resistance (20 °C)	Ω	Rotor : 0,640				Stator : 10,60				
Heat dissipation at f.l.cl.H	W	6000	5943	6114	5322	5852	6135	6260	6194	
Telephone Interference		THF < 2%				TIF < 50				
Radio interference		EN50081-1, EN50082-1, VDE0875K. For others standards apply to factory								
Waveform Distors.(THD) at f. load	LL/LN %	3,6 / 3,2								
Waveform Distors.(THD) at no load	LL/LN %	4,3 / 4								
<b>Mechanical characteristics</b>										
Protection		IP 21 (other protection on request)								
DE bearing		6312-2RS								
NDE bearing		6309-2RS								
Weight of wound stator assembly	kg	59,6								
Weight of wound rotor assembly	kg	41								
Weight of complete generator	kg	204								
Maximun overspeed	rpm	4320								
Unbalanced magnetic pull at f.l.cl.F	kN/mm	3,8								
Cooling air requirement	m³/min	22,4				27				
Inertia Constant (H)	sec.	0,345				0,414				
Noise level at 1m/7m	dB(A)	88 / 77				93 / 80				

**50 Hz**

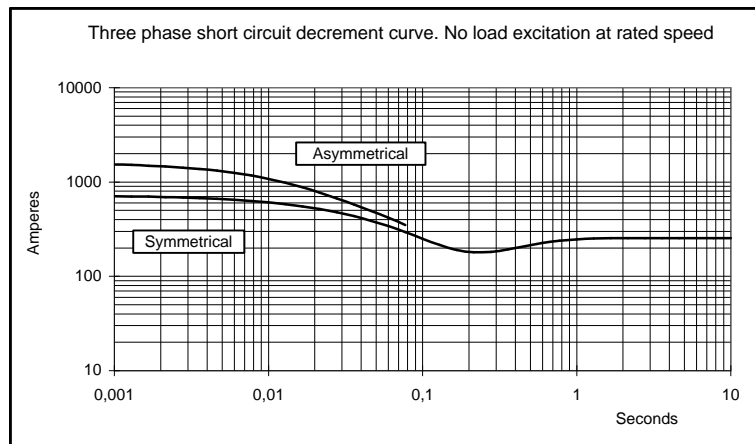

**60 Hz**

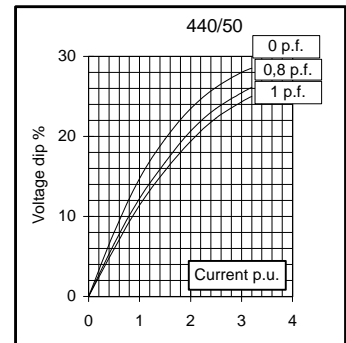
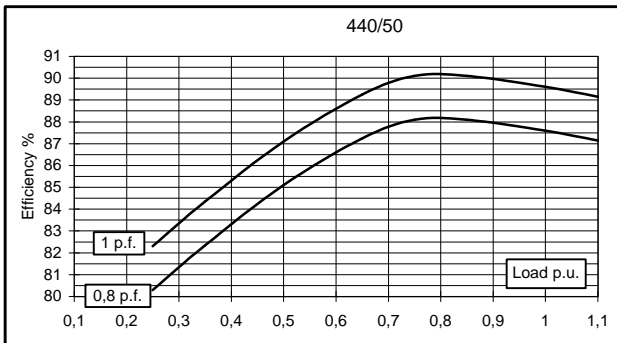
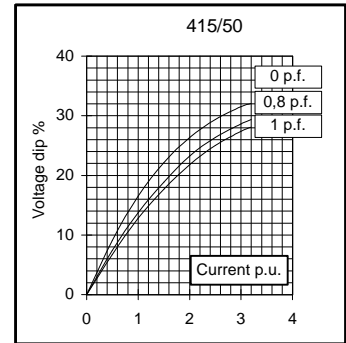
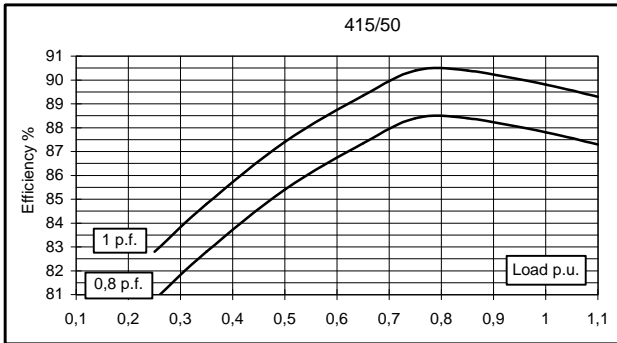
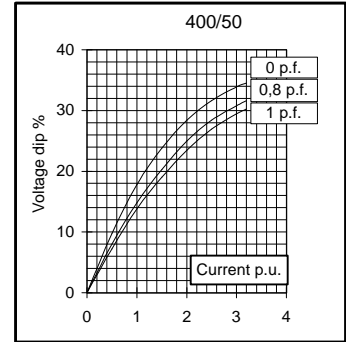
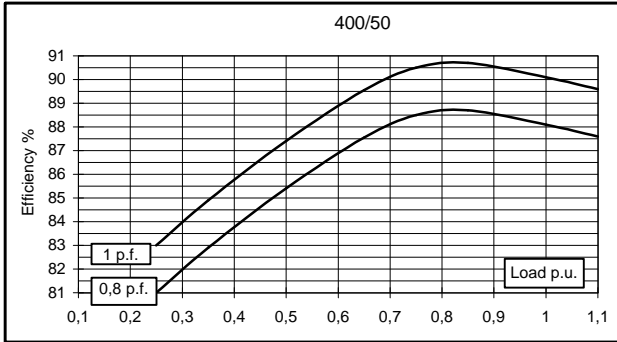
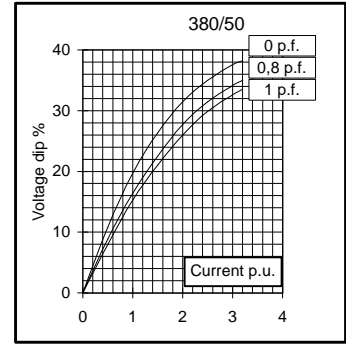
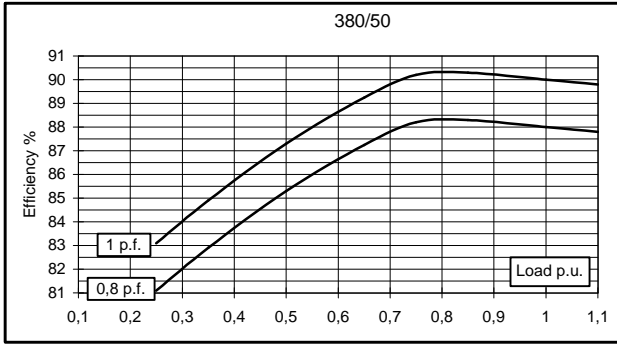
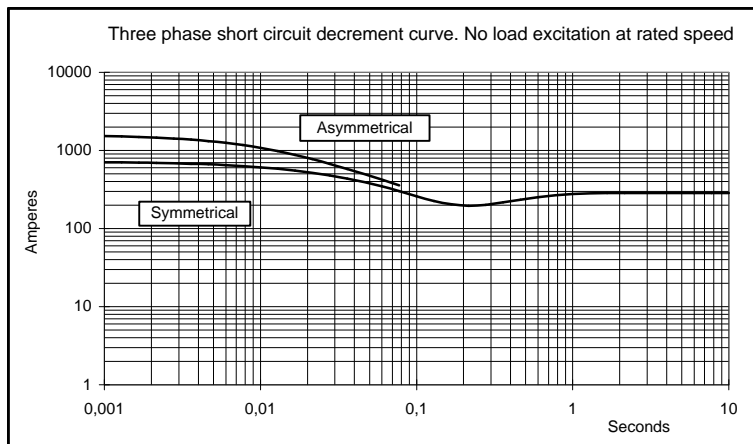
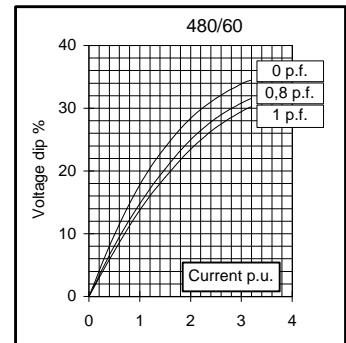
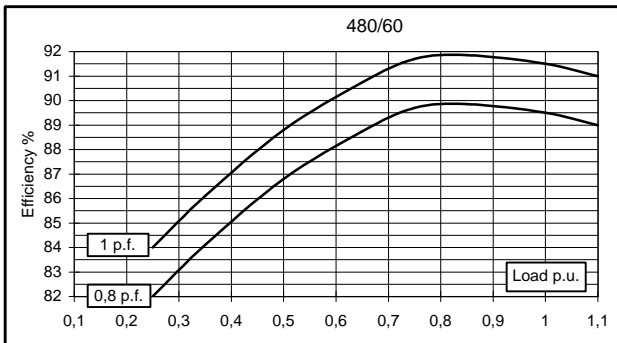
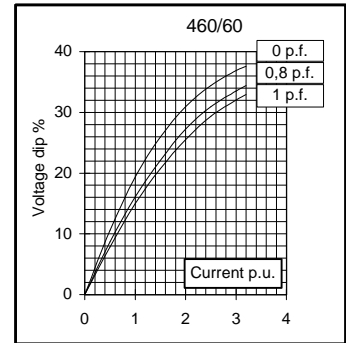
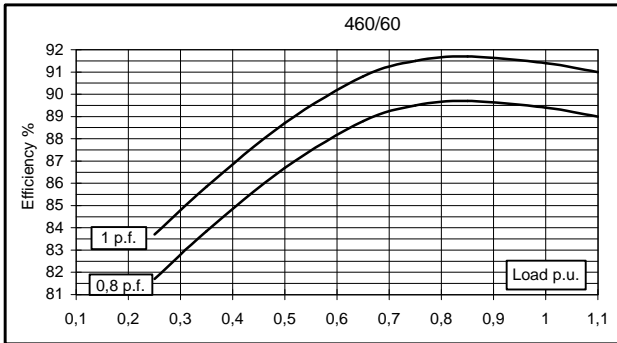
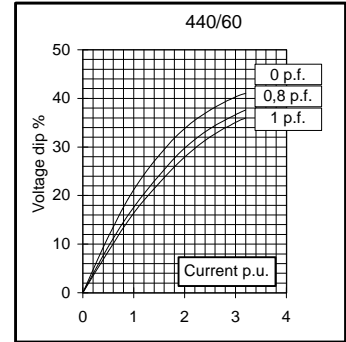
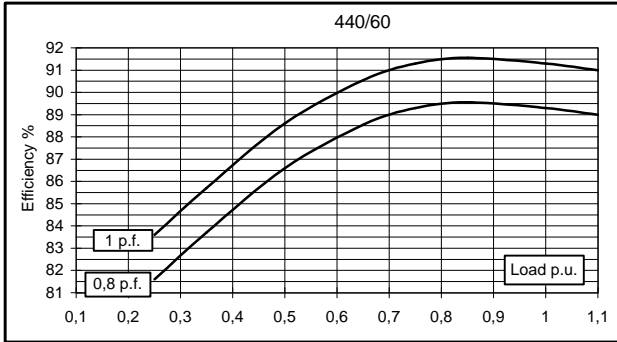
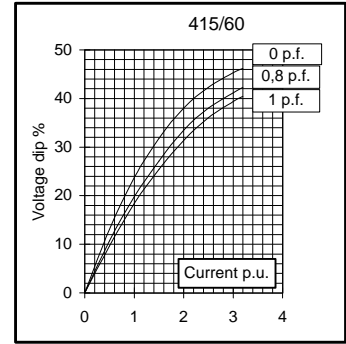
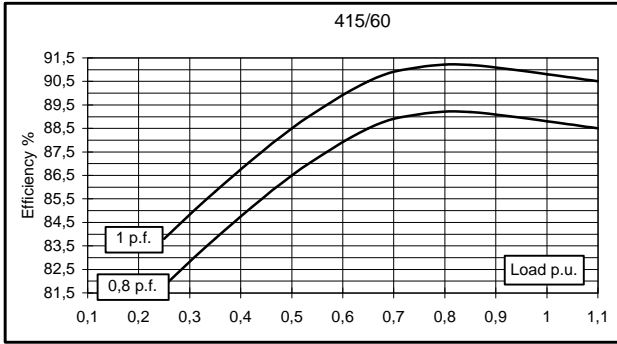



# SINGLE BEARING MOMENTS OF INERTIA

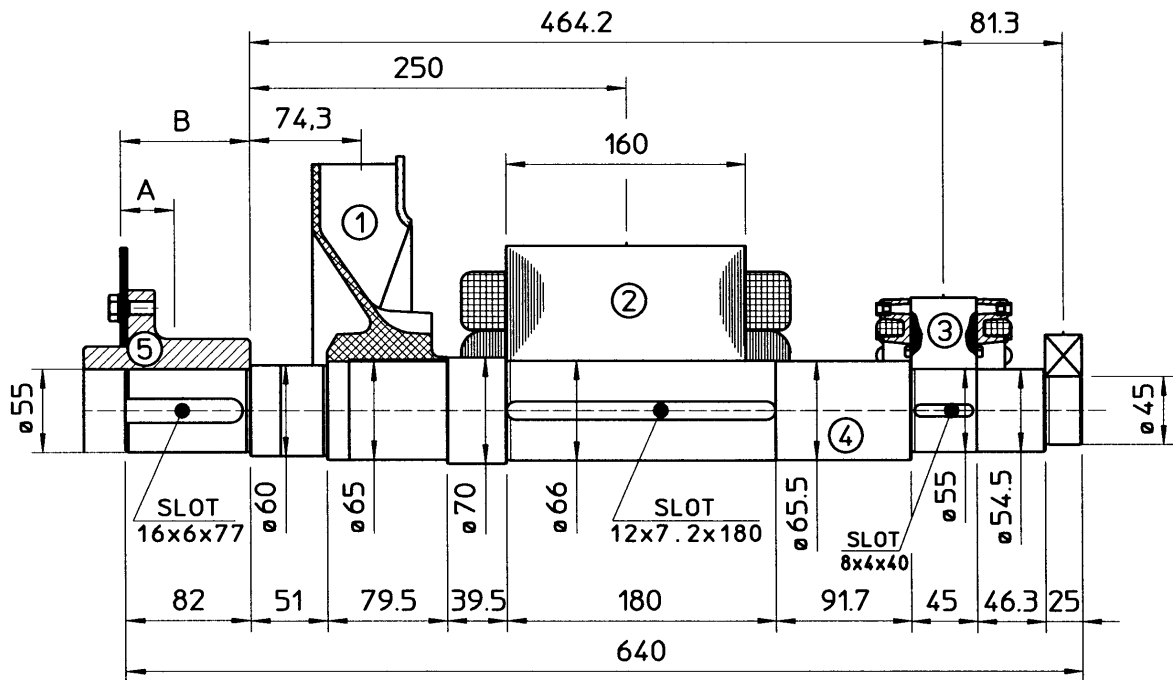

COMPONENT	WEIGHT kg	J kgm <sup>2</sup>
1 FAN	2.3	0.0224
2 MAIN ROTOR	36.3	0.136
3 EX. ROTOR	5.4	0.012
4 SHAFT	15.1	0.007
TOTAL	59.1	0.1774

SAE No	SHAFTS COUPLING FLEX PLATE			
	A	B	WEIGHT kg	J kgm <sup>2</sup>
6.5	26.1	75.2	4.2	0.0225
7.5	25.7	75.2	4.4	0.0256
8	38.25	106.9	7.2	0.0314
10	32.7	98.7	8.7	0.0485
11.5	24	84.5	8.3	0.0372

# SINGLE BEARING DIMENSIONS

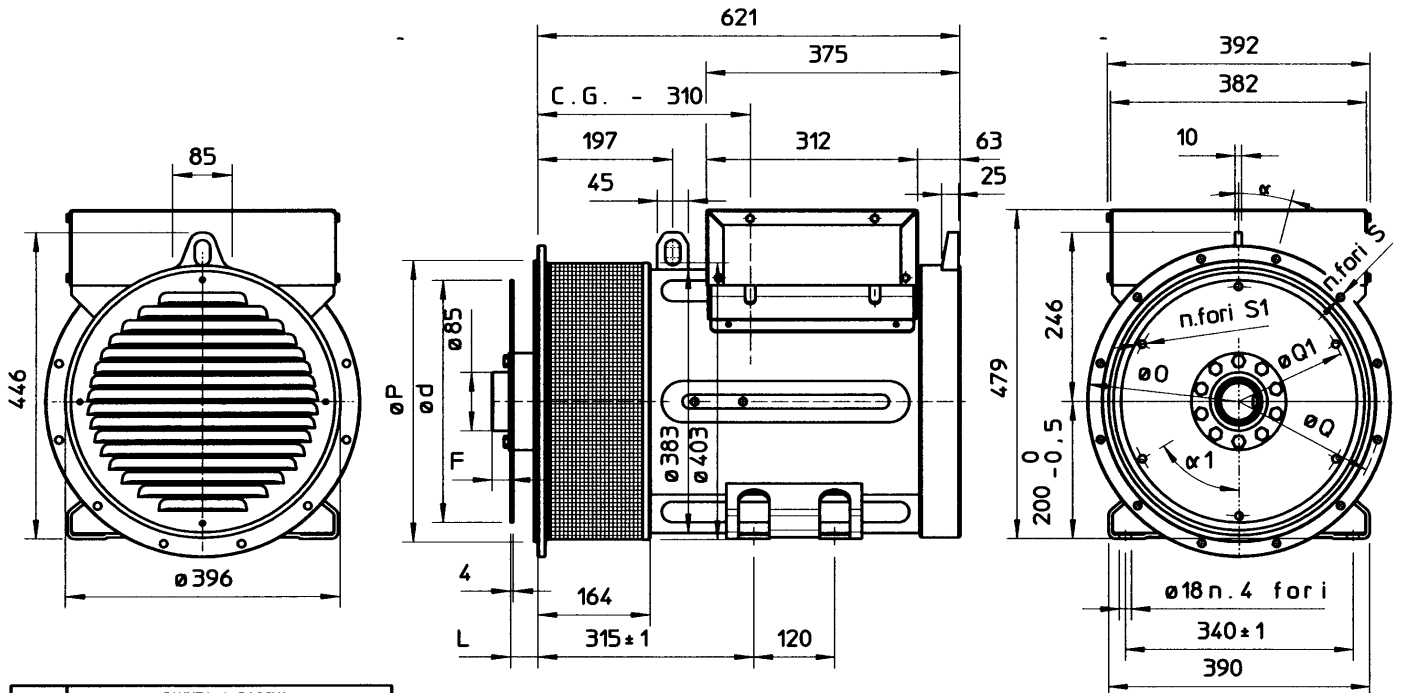

SAE N.	GIUNTI A DISCHI DISC COUPLING DISQUE DE MONOPALIER SCHEIBENKUPPLUNG						
	L	d	Q1	N. FORI	S1	α1	F
6 1/2	30.2	215.9	200	6	9	60°	7
7 1/2	30.2	241.3	222.25	8	9	45°	7
8	62	263.52	244.47	6	11	60°	2
10	53.8	314.32	295.27	8	11	45°	10
11 1/2	39.6	352.42	333.37	8	11	45°	24

SAE N.	FLANGIA / FLANGE BRIDE / FLANSCH						
	O	P	Q	N. FORI	S	α	
5	356	314.3	333.4	8	11	22°30'	
4	403	362	381	12	11	15°	
3	451	409.6	428.6	12	11	15°	
2	489	447.7	466.7	12	11	15°	
1	552	511.2	530.2	12	11	15°	

C.G. = GRAVITY CENTER