

Tipo Type Type Typ Tipo	115/230V 50Hz 3000 RPM					120/240V 60Hz 3600 RPM					Peso Weight Poids Gewicht Peso	J	T.H.D.			
	kVA	4/4 1 p.f. %	Volume d'aria Air volume Volume d'air Luftmenge Volumen de aire	Rumore Noise Bruit Gerausch Ruido		kVA	4/4 1 p.f. %	Volume d'aria Air volume Volume d'air Luftmenge Volumen de aire	Rumore Noise Bruit Gerausch Ruido					Kg	Kgm ²	%
				7m dBA	1m dBA				7m dBA	1m dBA						
				m ³ /min					m ³ /min							
	8,5	79	4,5	63	81	10,5	79,4	5,4	65	83	41,7	0,0219	< 4			
S20FS - 160/A	10	79,2	4,7	63	81	12	79,6	5,7	65	83	48,7	0,0261	< 4			
S20F - 200/A	12	80,3	4,7	63	81	14,4	80,8	5,7	65	83	56,5	0,0306	< 4			

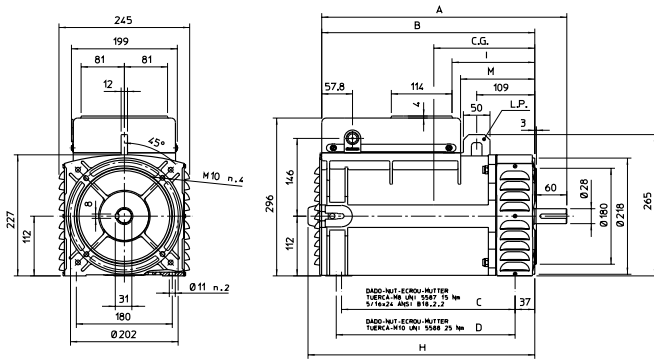

TIPO/TYP	A	B	C	D	H	I	M	L.P.
S20F	460	400	325,5	335,5	425,5	155	139	YES
S20FS	420	360	285,5	295,5	385,5	115	99	NO

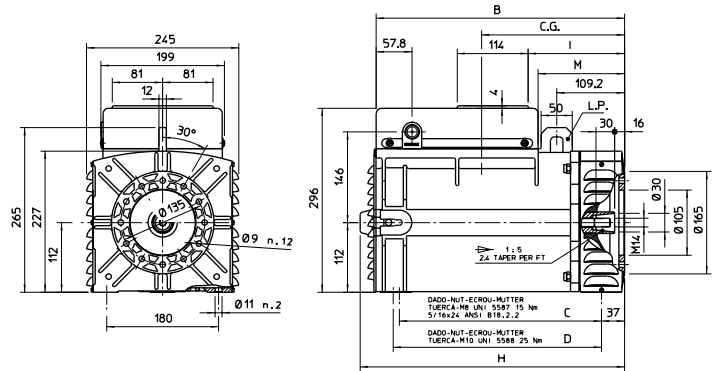

TIPO/TYP	B	C	D	H	I	M	L.P.
S20F	400	325,5	335,5	425,5	155	139	YES
S20FS	360	285,5	295,5	385,5	115	99	NO

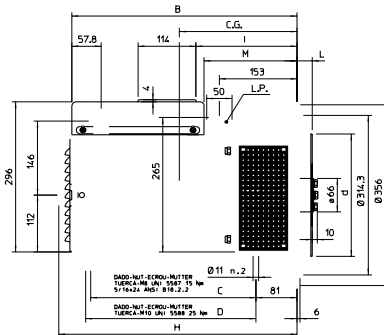

SAE N.	GIUNTI A DISCO - DISC COUPLING - ACC. DISQUE					
	L	d	Q1	n. fori	S1	
6 1/2	30,2	215,9	200	6	9	60
7 1/2	30,2	241,3	222,25	8	9	45

TIPO/TYP	B	C	D	H	I	M	L.P.
S20F	444	325,5	335,5	469,5	199	183	YES
S20FS	404	285,5	295,5	429,5	159	143	NO

CENTRO DI GRAVITA'Ø GRAVITY/CENTER CENTRE DE GRAVITE'Ø SCHWERPUNKT CENTROS DE GRAVEDAD		
CG		
FORMA FORM FORME	S20FS	S20F
J609b	130	160
B9/c30	217	220
MD35	251	244
B3/B14	215	208
	218	

CENTRO DI GRAVITA'Ø GRAVITY/CENTER CENTRE DE GRAVITE'Ø SCHWERPUNKT CENTROS DE GRAVEDAD		
CG		
FORMA FORM FORME	S20FS	S20F
J609b	130	160
B9/c30	217	220

FORMA FORM FORME	E	F	G
	J609b	∅146	∅165
	∅163,6	∅196,85	∅216
	∅177,8		



**ELENCO PARTI DI RICAMBIO / LIST OF SPARE PARTS /LISTE DES PIECES DETACHEES
ERSATZTEILLISTE / LISTA PARTES DE REPUESTO**

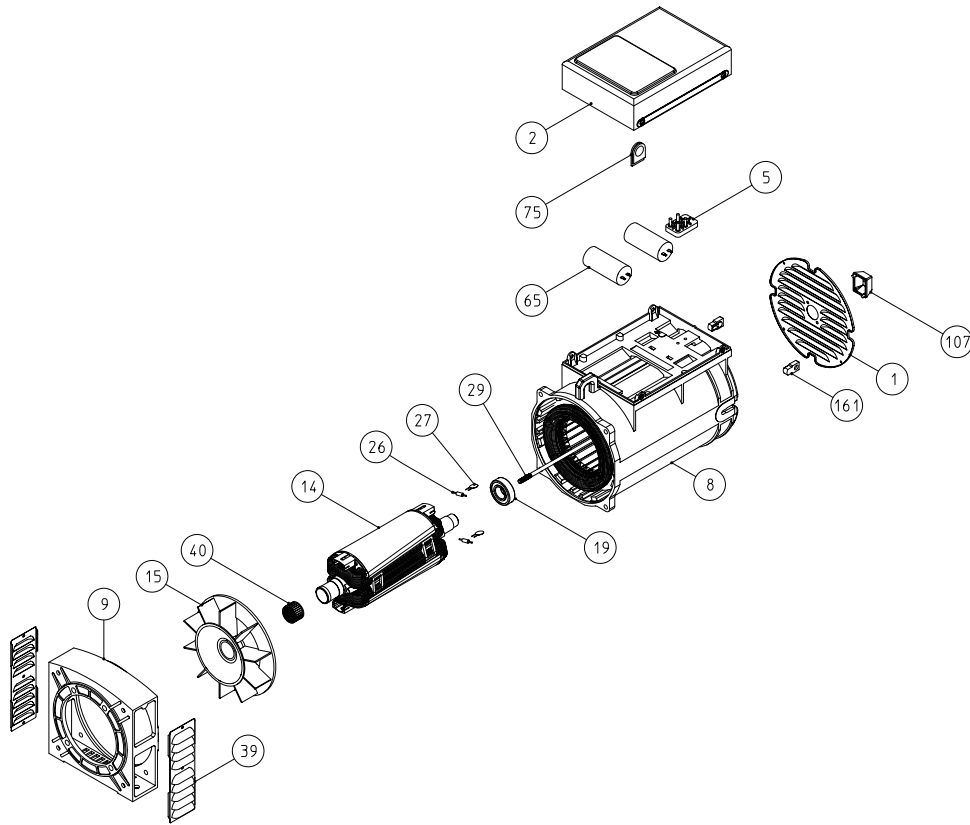

N.	DENOMINAZIONE	NAME	DESIGNATION	NAMEN	DENOMINACION	CODICE-CODE
1	CHIUSURA POSTERIORE	REAR SEAL	TOLE DE FERMETURE ARRIERE	HINTERER DECKEL	CIERRE POSTERIOR	0390700011
2	CUFFIA	TERMINAL BOX LID	COUVERCLE	DECKEL	TAPA	0390501015
5	MORSETTIERA UTILIZZAZIONE 56x36	TERMINAL BOARD 56x36	PLANCHETTE A' BORNES 56x36	KLEMBRETT	PLACA DE BORNES	9909915060
8	CARCASSA CON STATORE	FRAME AND STATOR	CARCASSE AVEC STATOR	GEHÄUSE MIT STATOR	CARCASA CON ESTATOR	-
9	COPERCHIO FORMA MD35	DRIVE END BRACKET MD35	FLASQUE MD35	FLANSCH MD35	BRIDA MD35	-
	COPERCHIO FORMA B9	DRIVE END BRACKET B9	FLASQUE B9	FLANSCH B9	BRIDA B9	-
	COPERCHIO FORMA B14	DRIVE END BRACKET B14	FLASQUE B14	FLANSCH B14	BRIDA B14	0391700143
14	INDUTTORE ROTANTE	ROTOR ASSY	INDUCTEUR TOURNANT	ROTIERENDER INDUKTOR	INDUCTOR ROTANTE	-
15	VENTOLA	FAN	VENTILATEUR	LÜFTER	VENTILADOR	0392000033
17	CUSCINETTO ANTERIORE 6306-2RS	FRONT BEARING 6306-2RS	ROULEMENT AVANT 6306-2RS	VORDERES LAGER 6306-2RS	COJINETE DELANTERO 6306-2RS	0390302532
19	CUSCINETTO POSTERIORE 6205-2RS	REAR BEARING 6205-2RS	ROULEMENT ARRIERE 6205-2RS	HINTERES LAGER 6205-2RS	COJINETE POSTERIOR 6205-2RS	0390302511
26	DIODO	DIODE	DIODE	DIODE	DIODO	9910356050
27	VARISTORE	VARISTOR	VARISTOR	VARISTOR	VARISTOR	9910384005
29	TIRANTE CENTRALE	SECURING STUD	TIGE CENTRALE	ZENTRIERSSTIFT	TIRANTE CENTRAL	-
39	RETINA DI PROTEZIONE	PROTECTION SCREEN	GRILLE DE PROTECTION	SCHÜTZGITTER	REJILLA DE PROTECCION	0390700009
40	ANELLO COMPENSATORE (MOD. BN 35x23)	FIXING RING (MOD. AN BN 35x23)	RONDILLE DE BLOUAGE(MOD. BN 35x23)	KOMPENSATOR RING (MOD. BN 35x23)	ANILLO COMPENSADORES (MOD. BN 35x23)	0390100211
65	CONDENSATORE	CAPACITOR	CONDENSATEUR	KONDENSATOR	CONDENSADOR	-
75	GOMMINO PASSACAVO	RUBBER GROMMET	PASSE-CABLES EN CAOUTCHOUC	GUMMI AUGE	GOMA PASACABLES	9909509081
107	TAPPO PER CUFFIA POSTERIORE	SECURING STUD CUP	BOUCHON POUR CAPOT ARRIERE	STÖPSEL FÜR HINTERES KLEMMKASTENDECKEL	GOMA PARA TAPA POSTERIOR	9909505006
161	GOMMINO	RUBBER-CUP	CAPOUCHON DE FERMETURE EN PLASTIQUE	SCHLUSSGUMMI	GOMA DE CIERRE	0390700306

N.B.- Nella richiesta di pezzi di ricambio specificare il tipo e il codice dell'alternatore.

When requesting spare parts always indicate the alternator's type and code.

Pour toute demande de pièces detachees, priere de mentionner le type et le code de l'alternateur.

Bei Ersatzteilbestellung bitte immer die Teilbenennung den Typ und den code des Wechselstromgenerators angeben.

En cada pedido de piezas de recambio especificar siembre el tipo y el codigo del alternador.