

**DIMENSIONI D'INGOMBRO / OVERALL DIMENSIONS / ENCOMBREMENT
BAUMASSE / DIMENSIONES MAXIMAS**

dimensions in mm

FORMA FORM FORME FORM FORMA B14

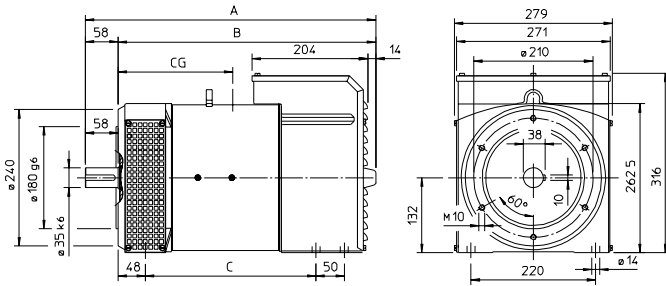

FORMA FORM FORME FORM FORMA B9

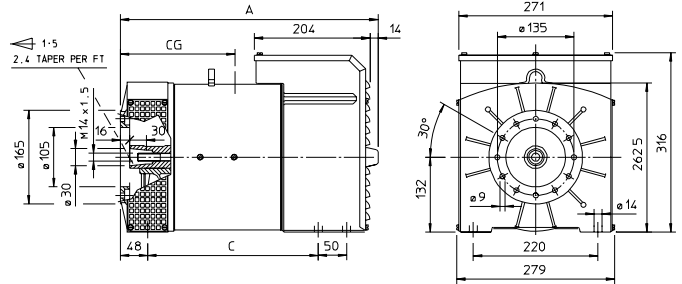

FORMA FORM FORME FORM FORMA J609b

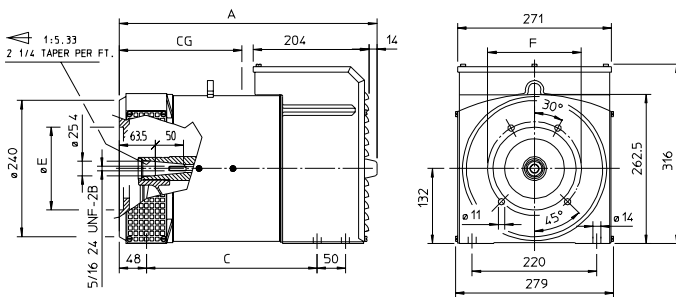

FORMA FORM FORME FORM FORMA MD35

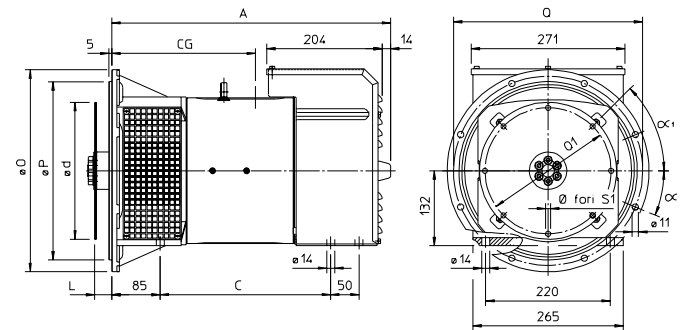

FORMA FORM FORME FORM FORMA		A	B	C	E	F
B14	S	511	454	301	-	-
	L	581	524	371	-	-
B9	S	454	-	301	-	-
	L	524	-	371	-	-
J609b	S	454	-	301	146,1	165,1
					163,6	196,8
	L	524	-	371	177,8	196,8
MD35	S	491	-	301	-	-
	L	561	-	371	-	-

FLANGIE - FLANGE - BRIDE - FLANSCH - BRIDAS					
SAE N.	O	P	Q	n.fori	α
6	308	266,7	285,75	8	22°30'
5	356	314,3	333,4	8	22°30'
4	403	362	381	12	15°
3	451	409,6	428,6	12	15°

CENTRO DI GRAVITA' - GRAVITY CENTER - CENTRE DE GRAVITE' - SCHWERPUNKT - CENTROS DE GRAVEDAD						
FORMA FORM FORME FORM FORMA	CG					
	1S	2S	1L	2L	3L	
B14	207	220	260	248	235	
B9	217	230	270	257	245	
J609b	217	230	270	257	245	
MD35	220	245	275	270	265	

GIUNTI A DISCO COUPLING DISCS DISQUE DE MONOPALIER SCHEIBENKUPPLUNGEN JUNTAS A DISCOS						
SAE N.	L	d	Q1	n. fori	S1	α 1
6 1/2	30,2	215,9	200	9	6	60°
7 1/2	30,2	241,3	222,25	9	8	45°
8	62	263,52	244,47	11	6	60°
10	53,8	314,52	295,27	11	8	45°
11 1/2	39,6	352,42	333,37	11	8	45°

**ALTERNATORE SERIE BTO3 - ELENCO PARTI DI RICAMBIO / ALTERNATOR SERIES BTO3 - LIST OF SPARE PARTS
ALTERNATEUR SERIE BTO3 - LISTE DES PIÈCES DÉTACHÉES / GENERATOR SERIE BTO3 - ERSATZTEILLISTE
ALTERNADOR SERIE BTO3 - LISTA PARTES DE REPUESTO**

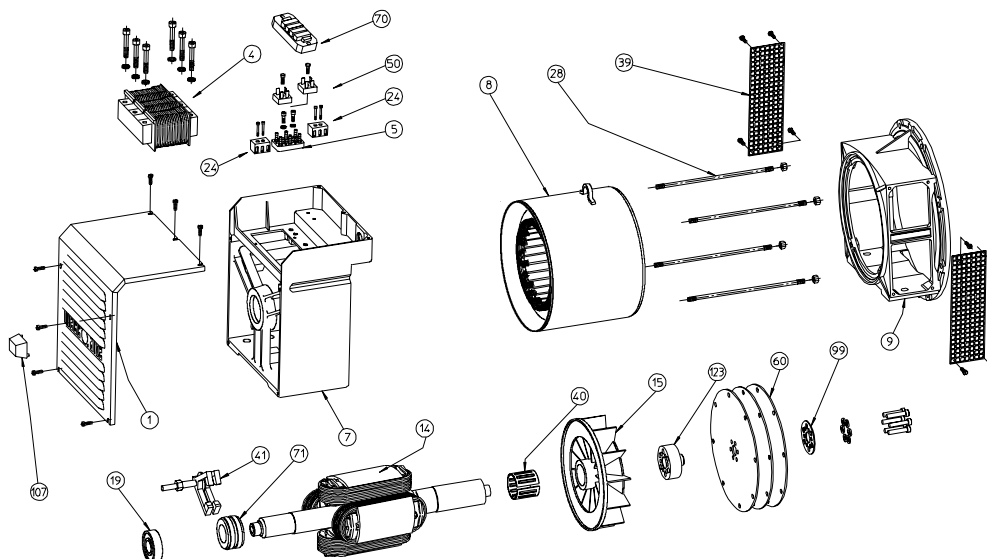

N.	DENOMINAZIONE	NAME	DESIGNATION	NAMEN	DENOMINACION	CODICE/CODE
1	CUFFIA	TERMINAL BOX LID	COUVERCLE	DECKEL	TAPA	7510607120
4	TRASFORMATORE COMPOUND	COMPOUNDING TRANSFORMER	TRASFORMATEUR DE COMPOUNDAGE	COMPOUND TRANSFORMATOR	TRANSFORMADOR COMPOUND	...
5	MORSETTIERA DI UTILIZZAZIONE	TERMINAL BOARD	PLANCHETTE À BORNES	KLEMMENBRETT	PLACA BORNES TERMINAL	9909915060
7	COPERCHIO POSTERIORE	NON DRIVE END BRACKET	FLASQUE ARRIERE	HINTERES GEHÄUSE	TAPA POSTERIOR	6102204138
8	CARCASSA CON STATORE 1S	FRAME AND STATOR 1S	CARCASSE AVEC STATOR 1S	GEHÄUSE MIT STATOR 1S	CARCASA CON ESTATOR 1S	3501572001
8	CARCASSA CON STATORE 2S	FRAME AND STATOR 2S	CARCASSE AVEC STATOR 2S	GEHÄUSE MIT STATOR 2S	CARCASA CON ESTATOR 2S	3501572002
8	CARCASSA CON STATORE 1L	FRAME AND STATOR 1L	CARCASSE AVEC STATOR 1L	GEHÄUSE MIT STATOR 1L	CARCASA CON ESTATOR 1L	3501572003
8	CARCASSA CON STATORE 2L	FRAME AND STATOR 2L	CARCASSE AVEC STATOR 2L	GEHÄUSE MIT STATOR 2L	CARCASA CON ESTATOR 2L	3501572004
8	CARCASSA CON STATORE 3L	FRAME AND STATOR 3L	CARCASSE AVEC STATOR 3L	GEHÄUSE MIT STATOR 3L	CARCASA CON ESTATOR 3L	3501572005
9	COPERCHIO ANTERIORE	DRIVE END BRACKET	FLASQUE AVANT	VORDERES GEHÄUSE	TAPA ANTERIOR	...
14	INDUTTORE ROTANTE	ROTOR ASSY	ROUE POLAIRE	ROTOR	INDUCTOR ROTANTE	...
15	VENTOLA	FAN	VENTILATEUR	LÜFTERRAD	VENTILADOR	...
17	CUSCINETTO ANTERIORE	FRONT BEARING	ROULEMENT AVANT	VORDERES LAGER	COJINETE ANTERIOR	9900905110
19	CUSCINETTO POSTERIORE	REAR BEARING	ROULEMENT ARRIERE	HINTERES LAGER	COJINETE POSTERIOR	9900905095
24	MORSETTERIA AUSILIARIA	AUXILIARY TERMINAL BOARD	BORNES AUXILIAIRES	NEBEN KLEMMBRETT	REGLETA	9909915225
28	TIRANTE COPERCHI S	COVER STAY BOLT S	TIGE DE FLASQUE S	STEBBOLZEN S	TIRANTE DE LA TAPA S	9911190240
28	TIRANTE COPERCHI L	COVER STAY BOLT L	TIGE DE FLASQUE L	STEBBOLZEN L	TIRANTE DE LA TAPA L	9911190241
29	TIRANTE CENTRALE	SECURING STUD	TIGE CENTRALE	ZENTRIERSSTIFT	TIRANTE CENTRAL	...
39	RETINA DI PROTEZIONE B9-B14	PROTECTION SCREEN B9-B14	GRILLE DE PROTECTION B9-B14	SCHUTZGITTER B9-B14	REJILLA DE PROTECCION B9-B14	8500626101
39	RETINA DI PROTEZIONE MD35	PROTECTION SCREEN MD35	GRILLE DE PROTECTION MD35	SCHUTZGITTER MD35	REJILLA DE PROTECCION MD35	8500626103
40	ANELLO COMPENSATORE SV 40x33	FIXING RING SV 40x33	RONDELLE DE BLOQUAGE SV 40x33	COMPENSATOR RING SV 40x33	ANILLO COMPENSADORES SV 40x33	9911141125
41	GRUPPO SPAZZOLE COMPLETO	BRUSH GEAR ASSEMBLY	ENSEMBLE PORTE BALAIS COMPLET	BURSTERNHALTER	PORTAESCOBILLAS	6101501110
50	PONTE RADDRIZZANTE A DIODI	DIODE-TYPE RECTIFYNG BRIDGE	PONT REDRESSEUR A DIODE	RICHTBRUCKE	PUENTE RECTIFICADOR	9910390215
60	DISCHI SAE 6.5	DISC PLATES SAE 6.5	DISQUES SAE 6.5	KUPPLUNGSSCHEIBEN SAE 6.5	DISCOS SAE 6.5	6110611150
60	DISCHI SAE 7.5	DISC PLATES SAE 7.5	DISQUES SAE 7.5	KUPPLUNGSSCHEIBEN SAE 7.5	DISCOS SAE 7.5	6110611152
60	DISCHI SAE 8	DISC PLATES SAE 8	DISQUES SAE 8	KUPPLUNGSSCHEIBEN SAE 8	DISCOS SAE 8	6110611154
60	DISCHI SAE 10	DISC PLATES SAE 10	DISQUES SAE 10	KUPPLUNGSSCHEIBEN SAE 10	DISCOS SAE 10	6110611156
60	DISCHI SAE 11.5	DISC PLATES SAE 11.5	DISQUES SAE 11.5	KUPPLUNGSSCHEIBEN SAE 11.5	DISCOS SAE 11.5	6110611158
70	FILTRO ANTIDISTURBO	RADIO INTERFERENCESUPPRESSOR	FILTRE ANTI-PARASITAGE	FÜNKENTSTOERFILTER	SUPRESORE RADIO	6101020020
71	COLLETTORE AD ANELLI	SLIPPING	BAGUES	BURSTENRING	COLECTOR DE ANILLOS	9909918047
99	ANELLO BLOCCAGGIO DISCHI	DISC LOCKING RING-SPACER	ANNEAU BLOCAGE DES DISQUES	SPANNRING DISTANZSCHEIBEN	ANILLO DE BLOC. DISCOS SEPARAD.	6110611508
107	TAPPO CUFFIA	RUBBER CAP	OBTURATEUR	GUMMISTOPFEN	TAPA DE GOMA	9909505006
123	ANELLO DISTANZIALE	RING SPACER	ANNEAU ESPACEUR	ABSTANDRING	ANILLO SEPARADORES	7502212040

N.B.- Nella richiesta di pezzi di ricambio specificare il tipo e il codice dell'alternatore.

When requesting spare parts always indicate the alternator's type and code.

Pour toute demande de pièces détachées, prière de mentionner le type et le code de l'alternateur.

Bei Ersatzteilbestellung bitte immer die Teilbenennung den Typ und den code des Wechselstromgenerators angeben.

En cada pedido de piezas de recambio especificar siempre el tipo y el código del alternador.