



COMPANY
WITH QUALITY SYSTEM
CERTIFIED BY DNV
ISO 9001

MR2

MECCALTE spa - Via Roma, 20 - 36051 CREAZZO (VI) ITALIA
Tel. 0444/396111 - Fax 0444/396166 - e-mail : mecc-alte-spa@meccalte.it
web site: www.meccalte.com

2 POLE 1 PHASE

CARATTERISTICHE / CHARACTERISTICS / CARACTERISTIQUES / TECHNISCHE MERKMALE / CARACTERISTICAS

Tipo Type Type Typ Tipo	115/230V 50Hz 3000 RPM					120/240V 60Hz 3600 RPM					Peso Weight Poids Gewicht Peso	J	T.H.D.
	kVA	η 4/4 1 p.f.	Volume d'aria Air volume Volume d'air Luftmenge Volumen de aire	Rumore Noise Bruit Gerausch Ruido		kVA	η 4/4 1 p.f.	Volume d'aria Air volume Volume d'air Luftmenge Volumen de aire	Rumore Noise Bruit Gerausch Ruido				
				7m dBA	1m dBA				7m dBA	1m dBA			
%	m³/min				%	m³/min							
MR2 - 160/2	8	78	4,7	63	81	9,6	78,6	5,7	65	83	50	0,0255	< 5
MR2 - 200/2	10	79,5	4,7	63	81	12	80	5,7	65	83	57	0,0292	< 5

DIMENSIONI D'INGOMBRO / OVERALL DIMENSIONS / ENCOMBREMEN / BAUMASSE / DIMENSIONES MAXIMAS

dimensions in mm.

FORMA FORM FORME B3 / B14

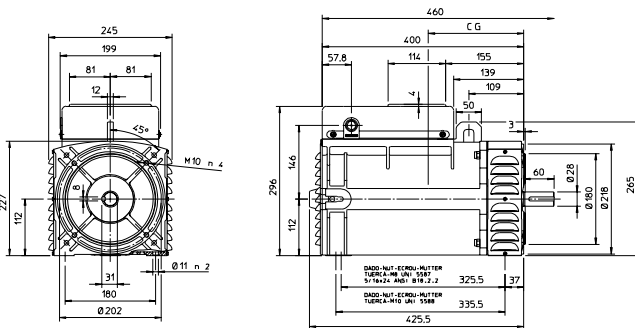

FORMA FORM FORME B9/c30

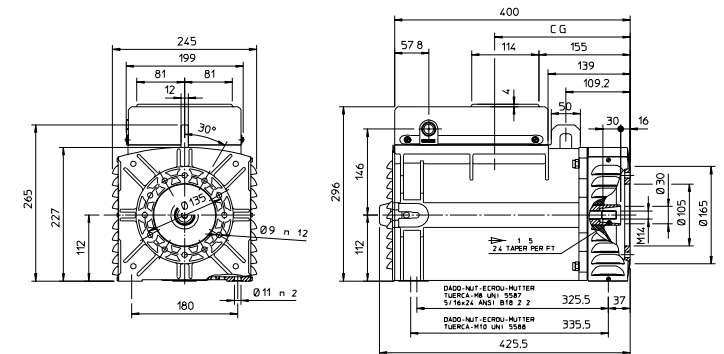

FORMA FORM FORME MD35

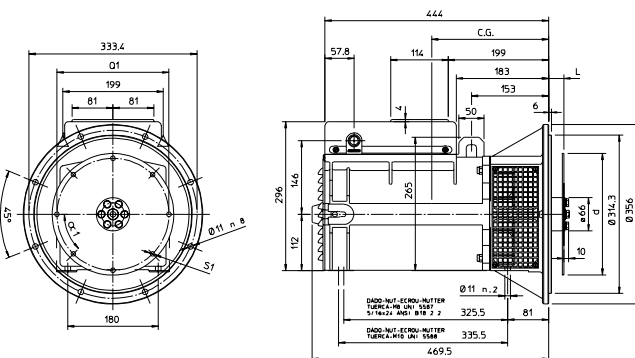

FORMA FORM FORME J609b

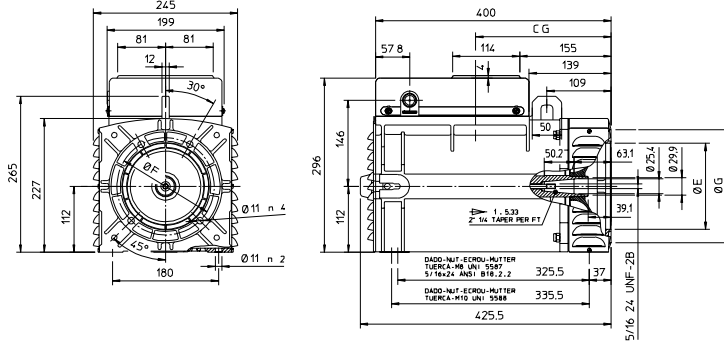

SAE N.	GIUNTI A DISCO / DISC COUPLING ACC. DISQUE					
	L	d	Q1	n. fori	S1	α 1
6 1/2	30,2	215,9	200	6	9	60°
7 1/2	30,2	241,3	222,25	8	9	45°

FORMA FORM FORME	MR2	
	160	200
MD35	264	254
B3/B14	228	218
J609b-B9/c30	230	220

FORMA FORM FORME	E	F	G
J609b	ø146	ø165	ø192
	ø163,6	ø196,85	ø216
	ø177,8		



**ELENCO PARTI DI RICAMBIO / LIST OF SPARE PARTS /LISTE DES PIECES DETACHEES
ERSATZTEILLISTE / LISTA PARTES DE REPUESTO**

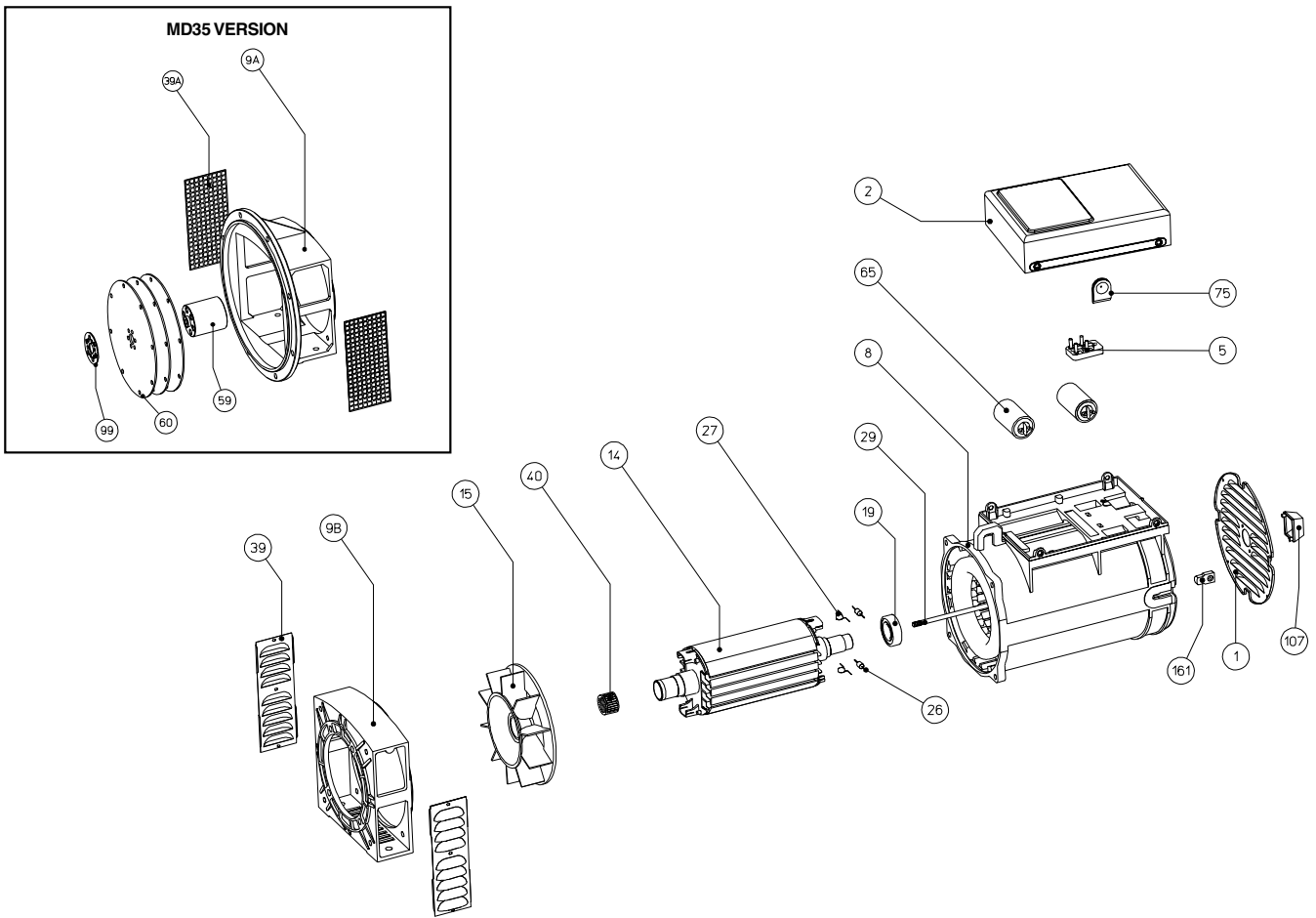

N.	DENOMINAZIONE	NAME	DESIGNATION	NAMEN	DENOMINACION	CODICE/CODE
1	chiusura posteriore	grid	grille de fermeture	gitter	rejilla	0390700011
2	cuffia	terminal box lid	couvercle	deckel	tapa	0390501015
5	morsettiera utilizzazione	terminal board	planchette à bornes	klemmenbrett	placa de bornes	9909915055
8	carcassa con statore	frame and stator	carcasse avec stator	gehäuse mit stator	carcaza con estator	***
9	coperchio anteriore B14	drive end bracket B14	flasque avant B14	worderer gehause B14	cierre anterior B14	0391700143
9A	coperchio anteriore MD35	drive end bracket MD35	flasque avant MD35	worderer gehause MD35	cierre anterior MD35	0391700144
9B	coperchio anteriore B9	drive end bracket B9	flasque avant B9	worderer gehause B9	cierre anterior B9	***
14	induttore rotante	rotating inductor	roue polaire	rotor	inductor rotante	***
15	ventola	fan	ventilateur	lüfterrad	ventilador	0392000033
17	cuscinetto anteriore 6306-2RS	drive end bearing 6306-2RS	roulement avant 6306-2RS	vorderes lager 6306-2RS	cojinete delantera 6306-2RS	0390302532
19	cuscinetto posteriore 6205-2RS	non drive end bearing 6205-2RS	roulement arrière 6205-2RS	hinteres lager 6205-2RS	cojinete posterior 6205-2RS	0390302511
26	diodo	diode	diode	diode	diode	9910356050
27	varistore	varistor	varistor	varistor	varistor	9910384005
29	tirante centrale	securing stud	tige central	zentriersstift	tirante central	***
39	retina protezione B14	protection screen B14	grille de protection B14	schutzgitter B14	rejilla protecciòn B14	0390700012
40	anello compensatore	fixing ring	rondelle de bloquage	kompensator ring	anillo compensadores	0390100211
59	mozzo porta dischi	coupling hub	manchon porte disques	nabe	cubo portadiscos	***
60	dischi	disc plates	disques	kupplungsscheiben	discos	***
65	condensatore	capacitor	condensateur	kondensator	condensator	***
75	gommino passacavo	cable grommet	passe cable en caout chouc	gummi auge	goma pasacables	9909509081
99	anello bloccaggio dischi	disc blocking ring	anneau blocage des disques	scheibenspanning	anillo de bloc. discos	***
107	tappo per cuffia	rubber cap	obtuteur	gummistopfen	goma para tapa	0391802007
161	gommino	rubber cup	capouchon de fermeture en plastique	schlussgummi	goma de cierre	0390700306

N.B.- Nella richiesta di pezzi di ricambio specificare il tipo e il codice dell'alternatore.

When requesting spare parts always indicate the alternator's type and code.

Pour toute demande de pièces détachées, prière de mentionner le type et le code de l'alternateur.

Bei Ersatzteilbestellung bitte immer die Teilbenennung den Typ und den code des Wechselstromgenerators angeben.

En cada pedido de piezas de recambio especificar siempre el tipo y el código del alternador.