



Alternatori Monofase 2 Poli

2 Pole Single-phase Alternators
Alternadores Monofásicos 2 Polos



SE100

brushless a condensatore

brushless, with capacitor
sin escobillas con condensador

SR100

a spazzole, con AVR

brushes, with AVR
con escobillas y AVR

SE100

Tensione standard: 50Hz: 230V, 240V 60Hz: 110/220V, 120/240V Altri valori a richiesta	Caratteristiche tecniche
Classe d'isolamento: H	
Protezione: IP 21 (optional IP 23)	
T.H.D. ≤ 6%	
Precisione tensione: + 5%, - 10% (cosφ = 1)	
Buona capacità di spunto (Icc = 3÷4In)	
Optional: Quadro elettrico, Carica batterie	

Standard Voltage: 50Hz: 230V, 240V 60Hz: 110/220V, 120/240V Other voltages on request	Technical characteristics
Insulation class: H	
Protection: IP 21 (optional IP 23)	
T.H.D. ≤ 6%	
Voltage accuracy: + 5%, - 10% (cosφ = 1)	
Good starting capacity (Icc = 3÷4In)	
Optional: Electrical panel, Battery charger	

Tensión estándar: 50Hz: 230V, 240V 60Hz: 110/220V, 120/240V Otros valores bajo pedido	Características técnicas
Clase de aislamiento: H	
Protección: IP 21 (optional IP 23)	
T.H.D. ≤ 6%	
Precisión de la tensión: + 5%, - 10% (cosφ = 1)	
Buena corriente de arranque (Icc = 3÷4In)	
Opcionales: Cuadro eléctrico, Carga baterías	

SR100

Tensione standard: 50Hz: range 110÷120/220÷240V 60Hz: range 110÷120/220÷240V Altri valori a richiesta	Caratteristiche tecniche
Classe d'isolamento: H	
Protezione: IP 21 (optional IP 23)	
T.H.D. ≤ 6%	
Precisione tensione: ± 2% (indipendente dal cosφ)	
Buona capacità di spunto	
Optional: Quadro elettrico, Carica batterie	
Regolatore elettronico AVR 520: • optional: possibilità di regolare la tensione a distanza	

Standard Voltage: 50Hz: range 110÷120/220÷240V 60Hz: range 110÷120/220÷240V Other voltages on request	Technical characteristics
Insulation class: H	
Protection: IP 21 (optional IP 23)	
T.H.D. ≤ 6%	
Voltage accuracy: ± 2% (regardless of cosφ)	
Good starting capacity	
Optional: Electrical panel, Battery charger	
AVR 520 electronic regulator • optional: possibility of voltage remote adjustment	

Tensión estándar: 50Hz: range 110÷120/220÷240V 60Hz: range 110÷120/220÷240V Otros valores bajo pedido	Características técnicas
Clase de aislamiento: H	
Protección: IP 21 (optional IP 23)	
T.H.D. ≤ 6%	
Precisión de la tensión: ± 2% (sin depender de cosφ)	
Buena corriente de arranque	
Opcionales: Cuadro eléctrico, Carga baterías	
Regulador electrónico AVR 520 • opcional: posibilidad de regulación de la tensión a distancia	

	50Hz – 3000rpm					60Hz – 3600rpm					Peso		
	Potenza Output Power Potencia		Potenza assorbita Driving Power Potencia absorbida			Potenza Output Power Potencia		Potenza assorbita Driving Power Potencia absorbida			B3/B9	B34	SAE
	cosφ 1	cosφ 0,8	4/4 cosφ 1		cosφ 1	cosφ 0,8	4/4 cosφ 1		[kW]	η%	[kg]	[kg]	[kg]
	S1 [kVA]	S2 [kVA]	S1 [kVA]	[kW]	η%	S1 [kVA]	S2 [kVA]	S1 [kVA]	[kW]	η%	[kg]	[kg]	[kg]
SE 100 C	2,7	3,0	---	3,8	71	3,5	3,8	---	4,8	72	16,5	---	---
SE 100 D	3,5	3,8	---	4,8	72	4,5	4,8	---	6,2	73	17,5	---	---
SE 100 E	4,2	4,5	---	5,7	73	5,5	6,0	---	7,4	74	20	---	---
SE 100 F	5,0	5,5	---	6,7	75	6,0	6,5	---	7,9	76	23	---	---
SE 100 FX	5,5	6,0	---	7,3	75,5	6,5	7,0	---	8,5	76,5	23,5	---	---
SE 100 G	6,0	6,5	---	7,9	76	7,2	7,7	---	9,3	77	25	---	---
SR 100 C	3,5	3,8	2,8	4,9	71	4,2	4,5	3,3	5,8	72	16,5	---	---
SR 100 D	4,0	4,4	3,2	5,6	72	5,0	5,5	4,0	6,8	73	17,5	---	---
SR 100 F	5,0	5,5	4,0	6,6	76	6,0	6,5	4,8	7,8	77	23	---	---
SR 100 G	6,0	6,5	4,8	7,8	77	7,2	7,7	5,7	9,2	78	25	---	---

B3/B9

J609A
C 19

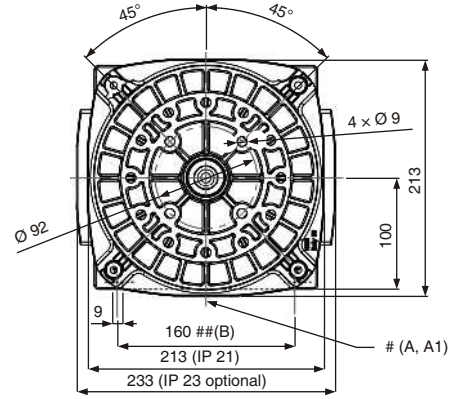
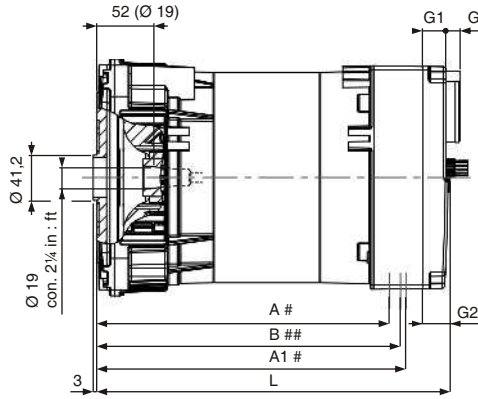

B3/B9

J609B
C 22
C 25,4

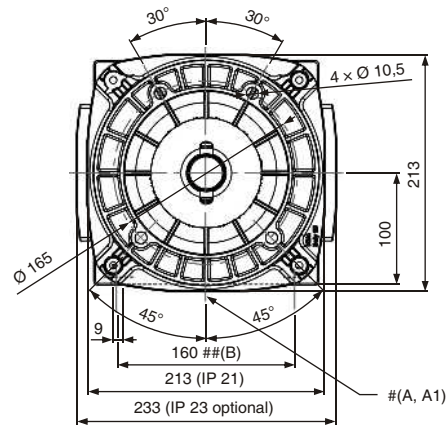
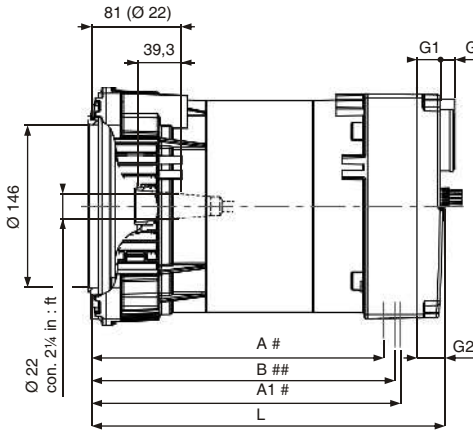

B3/B9

C 23

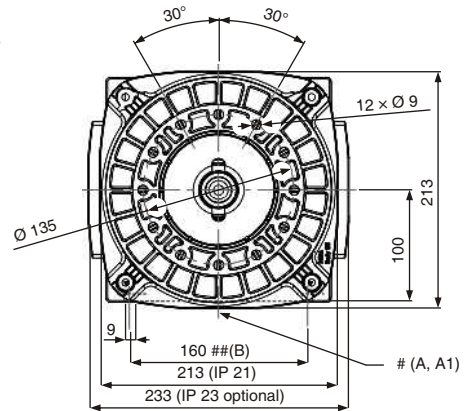
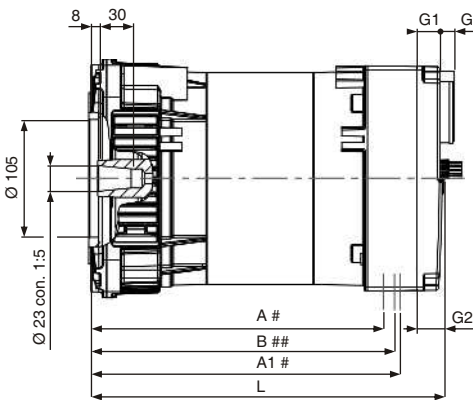

supporto antivibrante M8 (A) o M10 (A1) in posizione centrale
M8 (A) or M10 (A1) vibration-damping support in central position
soportes antivibrante M8 (A) o M10 (A1) en posición central

due supporti antivibranti M8 in posizione laterale (solo SE100)
two M8 vibration-damping supports in lateral position (only SE100)
dos soportes antivibrantes M8 en posición lateral (SE100)

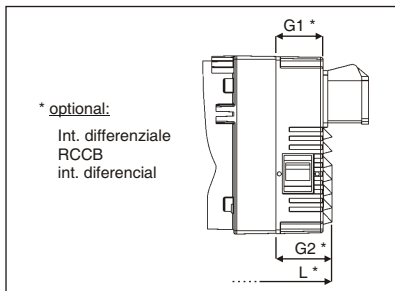

	A	A1	B	L	G1	G2
100 C	239+249	254+259	249+259	294	*332	21 *53 25 *63
100 D	249+259	264+269	259+269	304	*342	21 *53 25 *63
100 E	264+274	279+284	274+284	319	*357	21 *53 25 *63
100 F/FX	284+294	299+304	294+304	339	*377	21 *53 25 *63
100 G	299+309	314+319	309+319	354	*392	21 *53 25 *63

Prese

Sockets Tomas	Schuko	CEE 16A	CEE 32A	NEMA
G	13	51	61	1

Dati tecnici non impegnativi: NSM si riserva il diritto di apportare modifiche senza l'obbligo di darne preventiva comunicazione. Technical data not binding: NSM reserves the right to modify the contents without prior notice. Datos técnicos sin compromiso: NSM se reserva el derecho de aportar modificaciones sin la obligación de previo aviso.