

# T112 exploded view

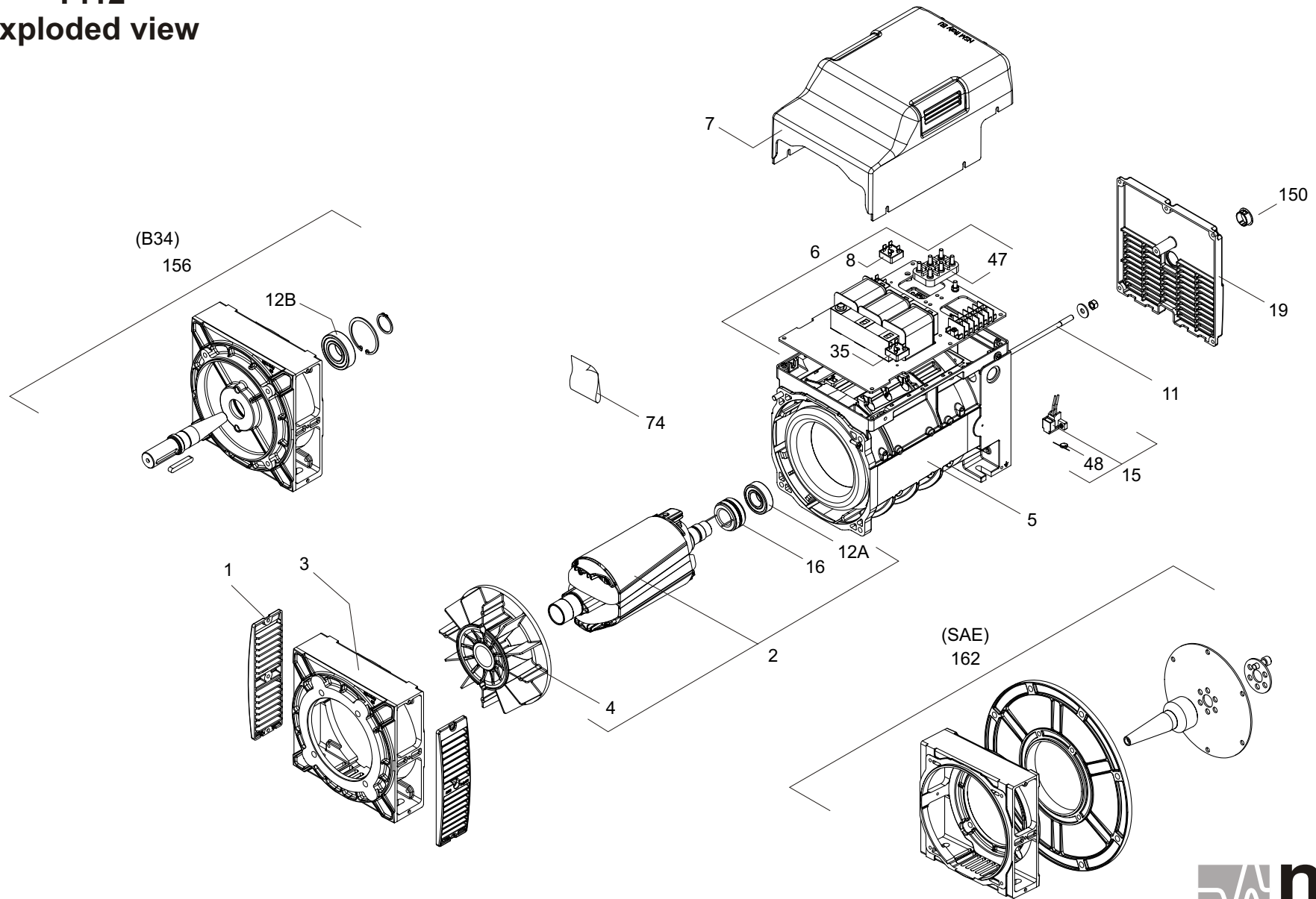

**Nomenclatura Ricambi T112 - T112 Spare Parts List - Pieces De Rechanges T112**

<b>N.</b>	<b>q.ty</b>	<b>descrizione</b>	<b>description</b>	<b>description</b>
1	2	cuffia espulsione aria IP23	IP23 outlet grid	Grille de protection IP23
2	1	Rotore avvolto completo (4-12A-16)	complete Wound rotor (with 4-12A-16)	Roue polaire bobiné complet (avec 4-12A-16)
3	1	scudo anteriore	drive end bracket	Flasque avant
4	1	ventola	fan	Ventilateur
5	1	Carcassa avvolta	Wound frame	Carcasse bobiné
6	1	Gruppo compound completo (con 8-47-[35])	complete compound set (with 8-47-[35])	Groupe compound complet (avec 8-47-[35])
7	1	coperchio chiuso o cablato	Blind or wired top cover	Couvercle sans trous o câblé
8	1	Ponte raddrizzatore alternatore	Alternator rectifier bridge	Pont redresseur de alternateur
11	1	Tirante rotore	rotor rod	Tige de roue polaire
12A	1	Cuscinetto	ball bearing	Roulement
12B	1	Cuscinetto per B34	Ball bearing for B34	Roulement pour B34
15	1	portaspazzole completo (con 48)	complete brush holder (with 48)	Porte-balais complete (avec 48)
16	1	Collettore	slip ring	Bagues
19	1	Cuffia aspirazione cieca o cablata	Blind or wired cover	Couvercle arriere sans trous o câblé
35	1	Ponte raddrizzatore per CB	B.C. rectifier bridge	Pont redresseur pour C.B.
47	1	morsettiera 6 perni	6 studs terminal board	Plaque à 6 bornes
48	1	Varistore	varistor	varistor
74	1	sacchetto viteria	assembling screw kit	Kit vis pour l'assemblage
150	1	tappo di chiusura	plastic plug	Bouchon
156	1	Kit scudo B34 (con 12B)	Drive end bracket kit for B34 (with 12B)	Kit Flasque avant pour B34 (avec 12B)
162	1	Kit SAE	Kit SAE	Kit SAE

nella richiesta di parti di ricambio, Vi preghiamo di comunicare sempre il tipo di alternatore/optional e le relative caratteristiche

On requesting of spare parts, please always indicate alternator/optional type and its characteristics

Nous vous prions d'indiquer toujours, dans vos commandes de pièces de rechanges, la description e les caracteristiques de la machine/optional

Contattare Ufficio Commerciale per quotazione ricambi: [info@nsmgenerators.com](mailto:info@nsmgenerators.com)

Contact Sales Office for quotatin request of spare parts: [info@nsmgenerators.com](mailto:info@nsmgenerators.com)

Contacter le Service Commercial pour quotation de pieces detacheés: [info@nsmgenerators.com](mailto:info@nsmgenerators.com)