



Alternatori sincroni trifasi
a 2 e 4 poli autoregolati
con spazzole.
Protezione: IP 23
Tensione standard: 231/400 V - 50 Hz
Corrente di cortocircuito superiore a 3.5 In
Forme costruttive: IM B34 - B3/B14, IM B35
B3/B9, IM B35 - J609b, SAE 4, SAE 5

Three-phase synchronous
self-regulated brushes
2 and 4 poles alternators.
Protection: IP 23
Standard voltage: 231/400 V - 50 Hz
Short circuit current greater than 3.5 In
Shape: IM B34 - B3/B14, IM B35
B3/B9, IM B35 - J609b, SAE 4, SAE 5



Caratteristiche tecniche 2 poli / *Technical characteristics 2 poles*

Tipo Type	Codice Code	50 Hz - 3000 r.p.m.		60 Hz - 3600 r.p.m.		Massa Mass kg
		Potenza Power kVA	η 4/4 $\cos\phi=0.8$ %	Potenza Power kVA	η 4/4 $\cos\phi=0.8$ %	
FT 2 MZS	81312120.2	12.0	82	15.0	84	42
FT 2 MAS	81312140.2	13.5	84	17.0	85	51
FT 2 MBS	81312160.2	16.0	85	20.0	86	60

Caratteristiche tecniche 4 poli / *Technical characteristics 4 poles*

Tipo Type	Codice Code	50 Hz - 1500 r.p.m.		60 Hz - 1800 r.p.m.		Massa Mass kg
		Potenza Power kVA	η 4/4 $\cos\phi=0.8$ %	Potenza Power kVA	η 4/4 $\cos\phi=0.8$ %	
FT 4 MAS	81314090.2	7.0	77	8.7	78	33
FT 4 MBS	81314120.2	9.0	79	11.2	80	40
FT 4 MCS	81314145.2	11.0	81	13.7	82	50
FT 4 MDS	81314170.2	13.0	83	16.2	84	60



Alternatori sincroni trifasi
a 2 e 4 poli con spazzole
e regolazione elettronica della tensione (AVR).
Protezione: IP 23
Tensione standard: 231/400 V - 50 Hz
Precisione di tensione: $\pm 2\%$
Forme costruttive: IM B34 - B3/B14, IM B35
B3/B9, IM B35 - J609b, SAE 4, SAE 5

Three-phase brushes synchronous
2 and 4 poles alternators
with electronic voltage regulation (AVR).
Protection: IP 23
Standard voltage: 231/400 V 50 Hz
Voltage accuracy: $\pm 2\%$
Shape: IM B34 - B3/B14, IM B35
B3/B9, IM B35 - J609b, SAE 4, SAE 5

Caratteristiche tecniche 2 poli / *Technical characteristics 2 poles*

Tipo Type	Codice Code	50 Hz - 3000 r.p.m.		60 Hz - 3600 r.p.m.		Massa Mass kg
		Potenza Power kVA	η 4/4 $\cos\phi=0.8$ %	Potenza Power kVA	η 4/4 $\cos\phi=0.8$ %	
FT 2 MZR	85312120.2	12.0	82	15.0	84	39
FT 2 MAR	85312140.2	13.5	84	17.0	85	48
FT 2 MBR	85312160.2	16.0	85	20.0	86	57

Caratteristiche tecniche 4 poli / *Technical characteristics 4 poles*

Tipo Type	Codice Code	50 Hz - 1500 r.p.m.		60 Hz - 1800 r.p.m.		Massa Mass kg
		Potenza Power kVA	η 4/4 $\cos\phi=0.8$ %	Potenza Power kVA	η 4/4 $\cos\phi=0.8$ %	
FT 4 MAR	85314090.2	7.0	77	8.7	78	30
FT 4 MBR	85314120.2	9.0	79	11.2	80	37
FT 4 MCR	85314145.2	11.0	81	13.7	82	47
FT 4 MDR	85314170.2	13.0	83	16.2	84	57

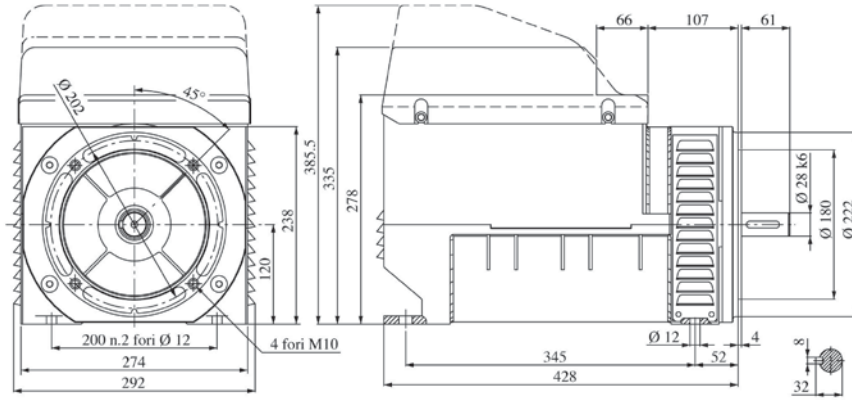

Forma costruttiva / Shape IM B34 - B3/B14 cod.E

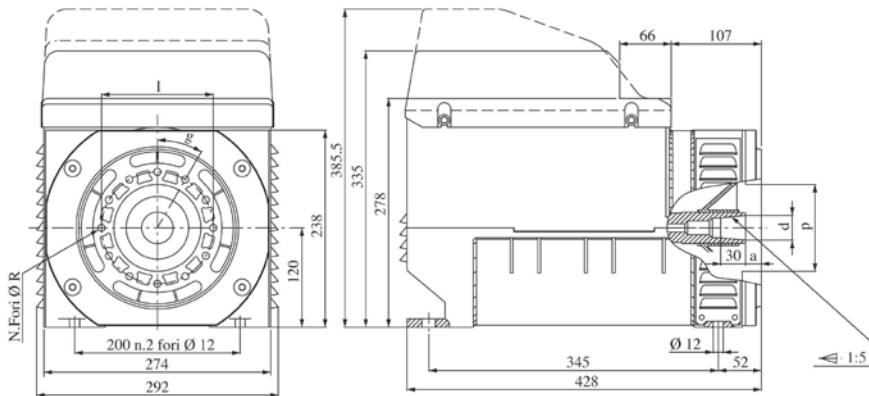

Albero Shaft		Flangia Flange			cod.	
d	a	I	p	N.Fori	R	g
30	16	135	105	12	9	30°
38	5	150	125	4	12	90°

Forma costruttiva / Shape IM B35 - B3/B9 cod.B/G

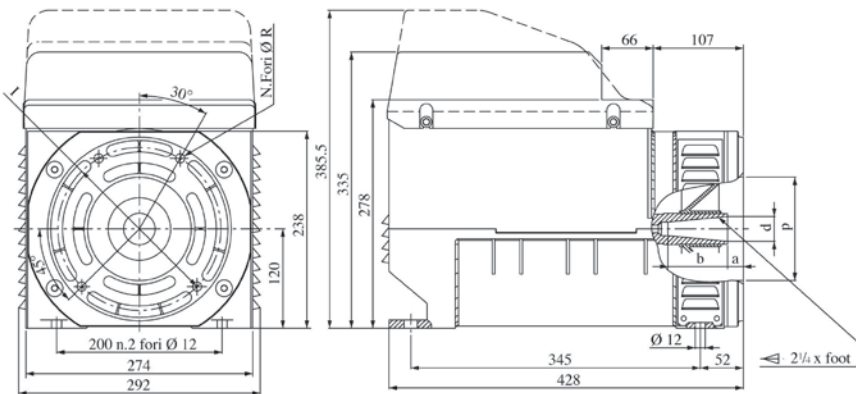

Cono Cone		Albero Shaft		cod.
d	a	b	D	
25.4	25.4	63.5	48	D
35	30	39	72	F

Flangia Flange			
I	p	N.Fori	R
165	146.1	4	11
197	163.6	4	11
197	177.8	4	11

Forma costruttiva / Shape IM B35 - J609b cod.D/F

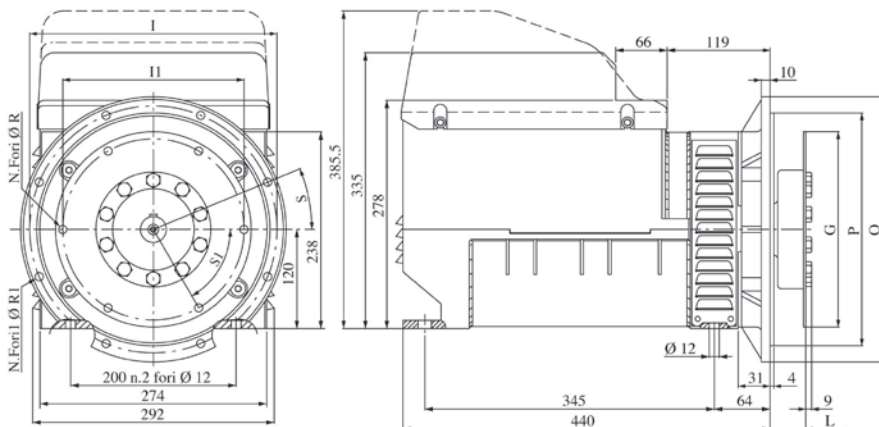

Flangia Flange						
SAE	Q	P	I	N.FORI	R	S
4	405	362	381	12	11	15°
5	358	314.3	333.4	8	11	22°30'

Giunto a dischi Disk joint						
SAE	L	G	I	N.FORI	R	S1
6.5	30.2	215.9	200	6	9	60°
7.5	30.2	241.3	222.2	8	9	45°
8.0	62.0	263.5	244.5	6	11	60°

Forma costruttiva / Shape SAE cod.4/5

