

FW4-dc

Saldatrici rotanti a corrente continua a 4 poli con spazzole. Protezione: IP 23
 Tipo di elettrodi saldabili: tutti i tipi inclusi basici e cellulosici. Regolazione elettronica della corrente di saldatura. Fornita di protezione termica autoripristinabile contro i sovraccarichi. Dotata di Arc Force (regolabile), Hot start, Antimpuntamento. Utilizzabile anche come alternatore
 Forme costruttive: IM B34 - B3/B14, IM B35 B3/B9, IM B35 - J609b, SAE 4, SAE 5

4 poles direct-current brushes rotating welders. Protection: IP 23
 Weldable electrodes: all types, included basic and cellulosic. Electronic regulation of welding current. Supplied with autoresettable thermal breaker against overload. Equipped with Tunable Arc Force, Hot Start and Anti Stick devices. Can also be used as alternator.
 Shape: IM B34 - B3/B14, IM B35 B3/B9, IM B35 - J609b, SAE 4, SAE 5



Caratteristiche tecniche saldatrice / Technical characteristics welder

Tipo Type	Codice Code	Velocità Speed rpm	Massa Mass IMB35 kg	Corrente di saldatura DC Welding current DC A	Tensione di innesco Strike voltage V	Tensione di saldatura Welding voltage V	Servizio Duty	Potenza assorbita Driving power
FW4 250 MDC	96314170.A2	1500	80	30÷250	70	21.2÷30	250A • 60 %	250A: 12 kW - 16Hp
FW4 250 TDC	96314170.X2	1500	80	30÷250	70	21.2÷30	250A • 60 %	250A: 12 kW - 16Hp
FW4 300 MDC	96314170.F2	1800	80	30÷300	70	21.2÷32	300A • 60 %	300A: 15kW - 20Hp
FW4 300 TDC	96314170.Q2	1800	80	30÷300	70	21.2÷32	300A • 60 %	300A: 15 kW - 20Hp

Caratteristiche tecniche alternatore / Technical characteristics alternator

Tipo Type	Codice Code	Trifase (cosφ=0.8) • Three phase (cosφ=0.8)				Monofase (cosφ=1) • Single phase (cosφ=1)			
		Potenza Power (S1) - kVA	Tensione Voltage V	Corrente (max S1) Current (max S1) A	Frequenza Frequency Hz	Potenza Power (S1) - kVA	Tensione Voltage V	Corrente (max S1) Current (max S1) A	Frequenza Frequency Hz
FW4 250 MDC	96314170.A2	-	-	-	-	5.0	230	21,7	50
FW4 250 TDC	96314170.X2	8	400	11.5	50	3.0	230	13,0	50
FW4 300 MDC	96314170.F2	-	-	-	-	7.0	240	29,2	60
FW4 300 TDC	96314170.Q2	10	416	13.8	60	4.0	240	16,6	60

NUOVA TECNOLOGIA
ELETTRONICA A CHOPPER

NEW CHOPPER
ELECTRONIC TECHNOLOGY

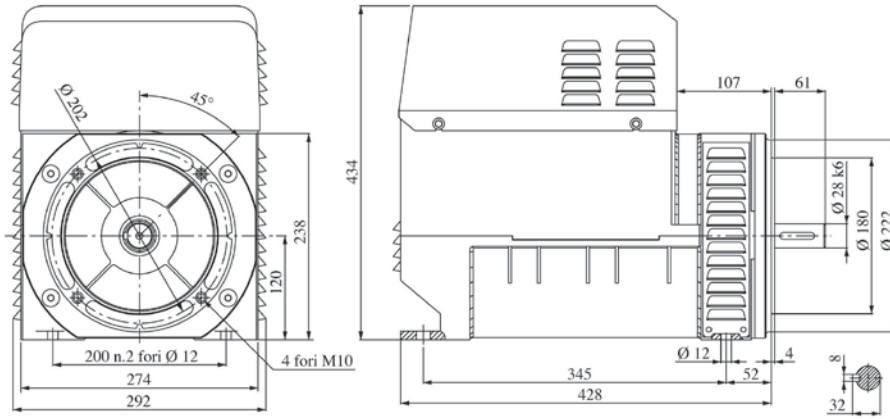

Forma costruttiva / Shape IM B34 - B3/B14 cod.E

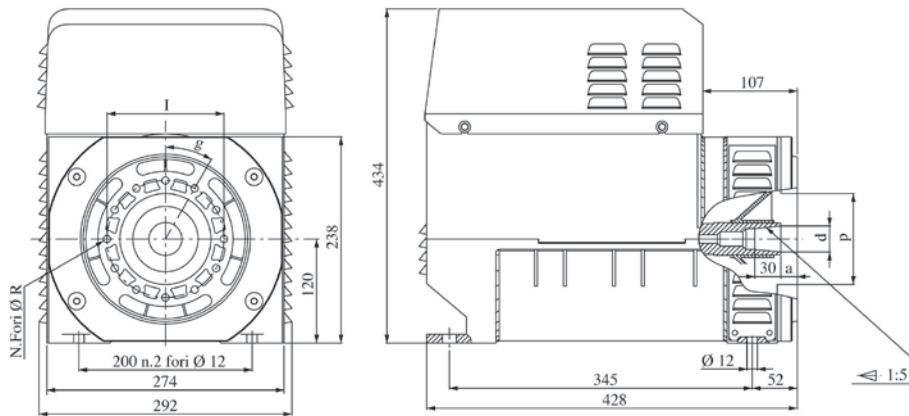

Albero Shaft		Flangia Flange				cod.
d	a	I	p	N.Fori	R	
30	16	135	105	12	9	30° B
38	5	150	125	4	12	90° G

Forma costruttiva / Shape IM B35 - B3/B9 cod.B/G

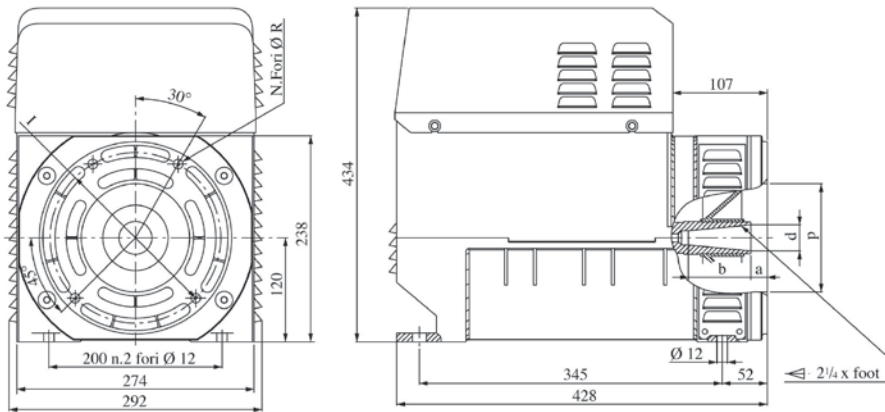

Cono Cone	Albero Shaft			cod.
	d	a	b	
25.4	25.4	63.5	48	D
35	30	39	72	F

Flangia Flange			
I	p	N.Fori	R
165	146.1	4	11
197	163.6	4	11
197	177.8	4	11

Forma costruttiva / Shape IM B35 - J609b cod.D/F

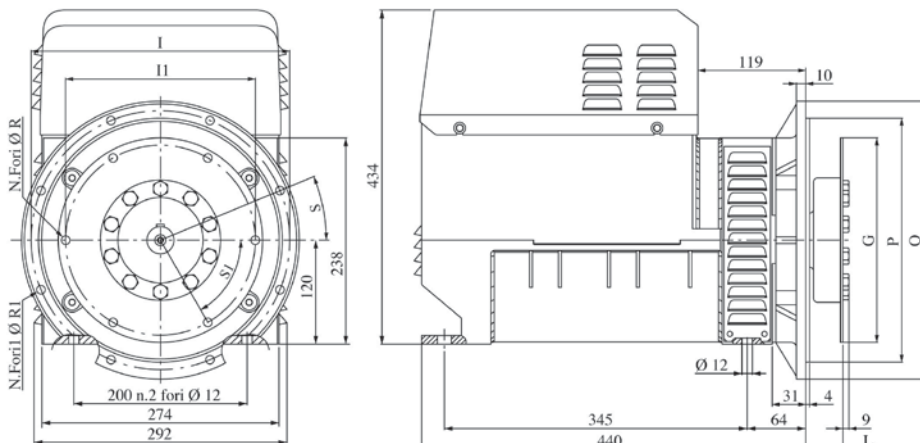

SAE	Flangia Flange					
	Q	P	I	N.FORI	R1	S
4	405	362	381	12	11	15°
5	358	314.3	333.4	8	11	22°30'

SAE	Giunto a dischi Disk joint					
	L	G	II	N.FORI	R	S1
6.5	30.2	215.9	200	6	9	60°
7.5	30.2	241.3	222.2	8	9	45°

Forma costruttiva / Shape SAE cod.4/5

