



Alternatori sincroni monofasi
a 2 e 4 poli autoregolati
senza spazzole.
Protezione: IP 21
Tensione standard: 115/230 V - 50 Hz
Corrente di cortocircuito superiore a 3 In
Forme costruttive: IM B34 - B3/B14, IM B35
B3/B9, IM B35 - J609b, SAE 4, SAE 5

Single-phase synchronous
self-regulated brushless
2 and 4 poles alternators.
Protection: IP 21
Standard voltage: 115/230 V - 50 Hz
Short circuit current greater than 3 In
Shape: IM B34 - B3/B14, IM B35
B3/B9, IM B35 - J609b, SAE 4, SAE 5



Caratteristiche tecniche 2 poli / *Technical characteristics 2 poles*

Tipo Type	Codice Code	50 Hz - 3000 r.p.m.		60 Hz - 3600 r.p.m.		IM B34 • IM B35 kg	SAE 4 • SAE 5 kg
		Potenza Power kVA	η 4/4 $\cos\phi=1$ %	Potenza Power kVA	η 4/4 $\cos\phi=1$ %		
GK 2 MAL	81206145..2	15.0	79	18.5	80	68	76
GK 2 MBL	81206170..2	17.5	80	22.0	82	88	96

Caratteristiche tecniche 4 poli / *Technical characteristics 4 poles*

Tipo Type	Codice Code	50 Hz - 1500 r.p.m.		60 Hz - 1800 r.p.m.		IM B34 • IM B35 kg	SAE 4 • SAE 5 kg
		Potenza Power kVA	η 4/4 $\cos\phi=1$ %	Potenza Power kVA	η 4/4 $\cos\phi=1$ %		
GK 4 MBL	84204170..2	10.0	81	12.5	82	78	86



Alternatori sincroni trifasi
a 2 e 4 poli autoregolati
con spazzole.
Protezione: IP 21
Tensione standard: 231/400 V - 50 Hz
Corrente di cortocircuito superiore a 3.5 In
Forme costruttive: IM B34 - B3/B14, IM B35
B3/B9, IM B35 - J609b, SAE 4, SAE 5

Three-phase synchronous
self-regulated brushes
2 and 4 poles alternators.
Protection: IP 21
Standard voltage: 231/400 V - 50 Hz
Short circuit current greater than 3.5 In
Shape: IM B34 - B3/B14, IM B35
B3/B9, IM B35 - J609b, SAE 4, SAE 5

Caratteristiche tecniche 2 poli / *Technical characteristics 2 poles*

Tipo Type	Codice Code	50 Hz - 3000 r.p.m.		60 Hz - 3600 r.p.m.		IM B34 • IM B35 kg	SAE 4 • SAE 5 kg
		Potenza Power kVA	η 4/4 $\cos\phi=0.8$ %	Potenza Power kVA	η 4/4 $\cos\phi=0.8$ %		
GT 2 MAS	81306145..2	22.0	83	27.5	84	74	82
GT 2 MBS	81306170..2	27.0	85	34.0	86	84	92

Caratteristiche tecniche 4 poli / *Technical characteristics 4 poles*

Tipo Type	Codice Code	50 Hz - 1500 r.p.m.		60 Hz - 1800 r.p.m.		IM B34 • IM B35 kg	SAE 4 • SAE 5 kg
		Potenza Power kVA	η 4/4 $\cos\phi=0.8$ %	Potenza Power kVA	η 4/4 $\cos\phi=0.8$ %		
GT 4 MBS	84304170..2	16.0	82	20.0	83	86	94

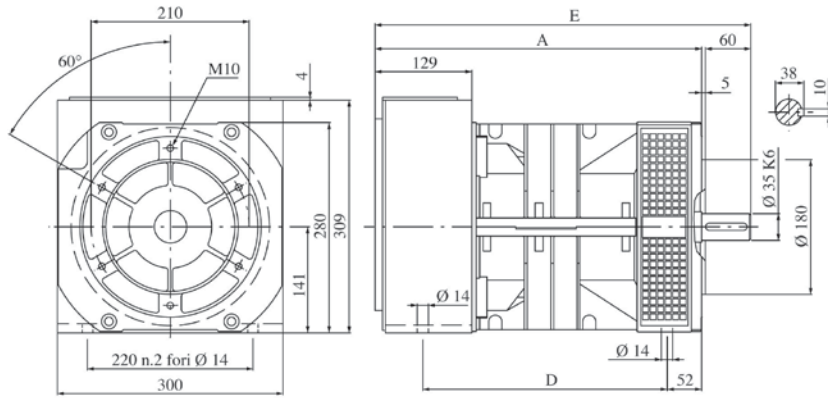

Tipo Type	A	D	E
GK-M / GT-M	498	382	563

Forma costruttiva / Shape IM B34 - B3/B14 cod.E

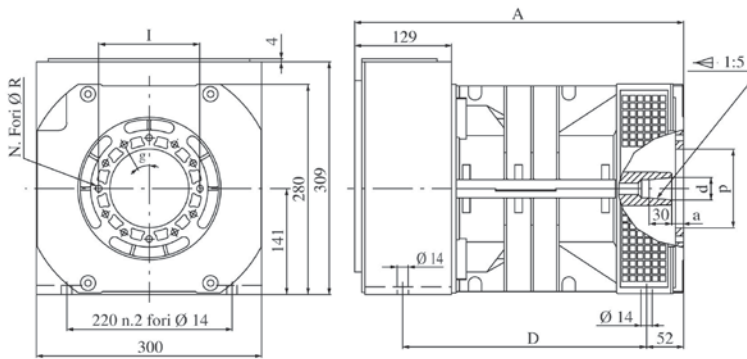

Tipo Type	A	D
GK-M / GT-M	498	382

Albero Shaft		Flangia Flange				cod.
d	a	I	p	N.Fori	R	g
30	16	135	105	12	9	30° B
38	5	150	125	4	12	90° G

Forma costruttiva / Shape IM B35 - B3/B9 cod.B/G

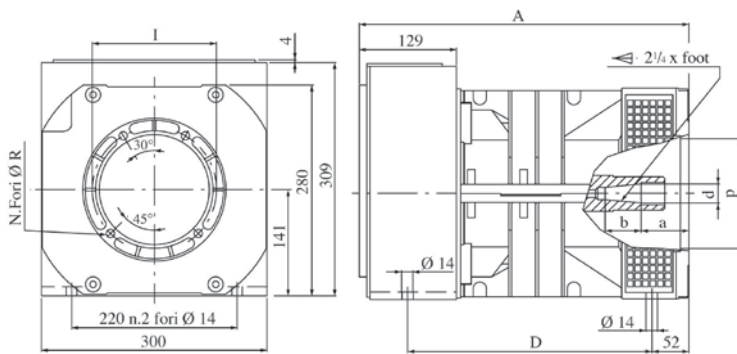

Tipo Type	A	D
GK-M / GT-M	498	382

Albero Shaft		cod.
d	a	b
35	12.4	71 F

Flangia Flange			
I	p	N.Fori	R
165	146.1	4	11
197	163.6	4	11
197	177.8	4	11

Forma costruttiva / Shape IM B35 - J609b cod.F

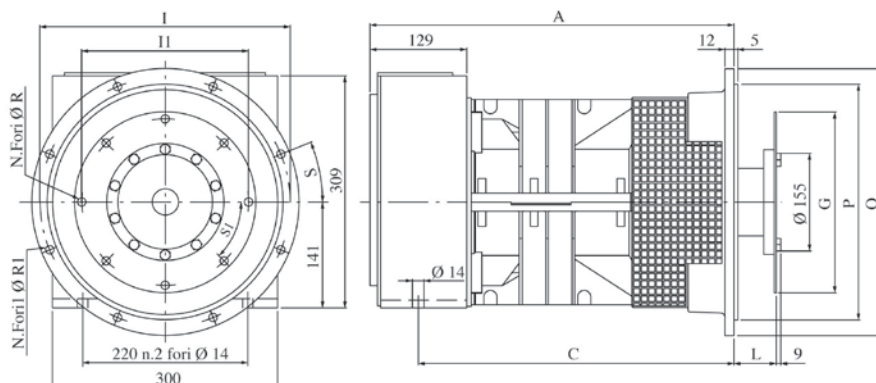

Tipo Type	A	C
GK-M / GT-M	545	481

Flangia Flange SAE					
Q	P	I	N.Foril	R1	S
4	405	362	381	12	11 15°
5	358	314.3	333.4	8	11 22°30'

Giunto a dischi Disk joint SAE					
L	G	I1	N.Foril	R	S1
6.5	30.2	215.9	200	6	9 60°
7.5	30.2	241.3	222.2	8	9 45°
8	62	263.5	244.5	6	11 60°
10	53.8	314.3	295.3	8	11 45°

Forma costruttiva / Shape SAE cod.4/5

